

VII. Structural Design

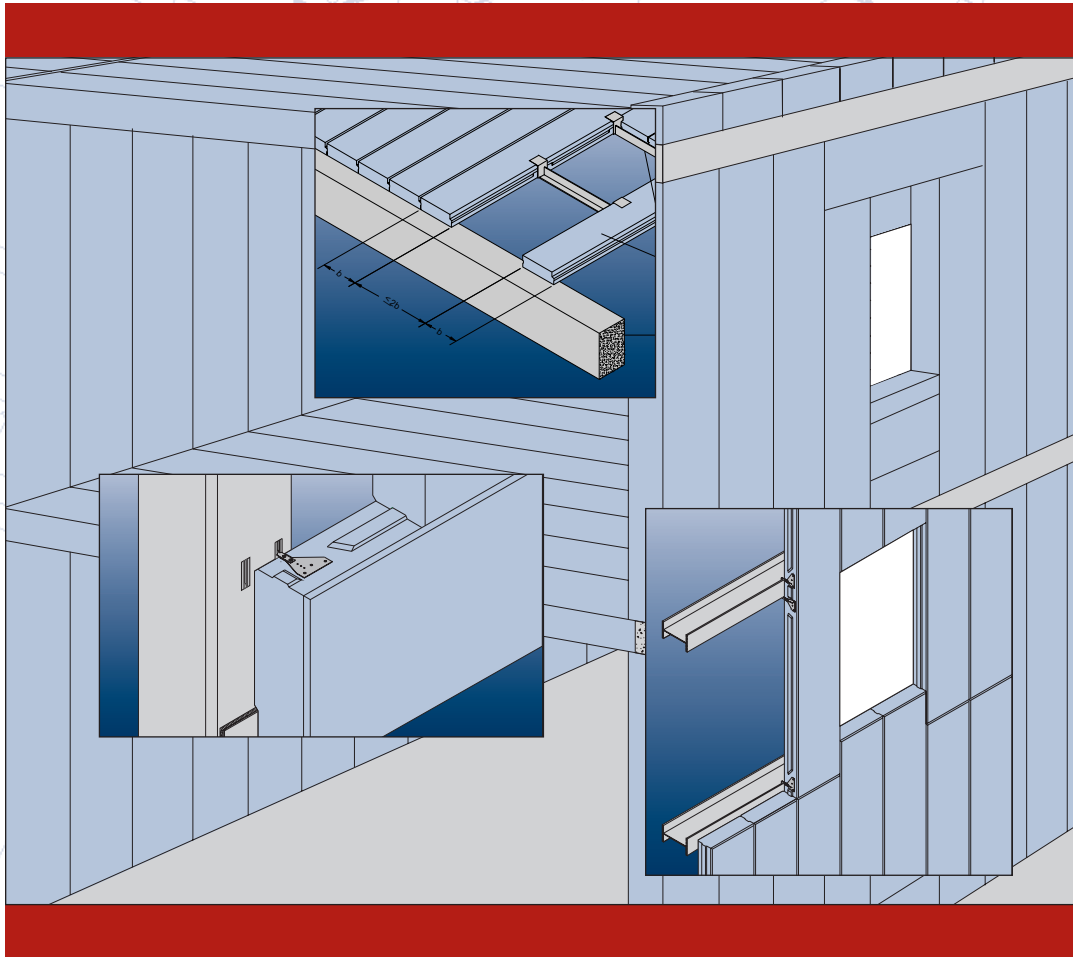

A. General	Page VII-2
B. Floor Panels	Page VII-3
C. Roof Panels	Page VII-6
D. Diaphragm Analysis	Page VII-10
E. Non-Load Bearing Wall Panels	Page VII-15
F. Load Bearing Vertical Wall Panels	Page VII-21
G. Blocks and Lintels	Page VII-24
H. Fasteners	Page VII-39
I. Notation	Page VII-42

A. General

The following topics in this section show the method for the structural design of AERCON panel and block systems.

Included are:

- Span graphs and diaphragm analysis for floor panels and roof panels

- Span graph and connections for non-load bearing wall panels
- Load bearing and shear wall analysis for load bearing vertical wall panels and blocks

For additional applications with other AERCON building systems, please consult an AERCON Representative.

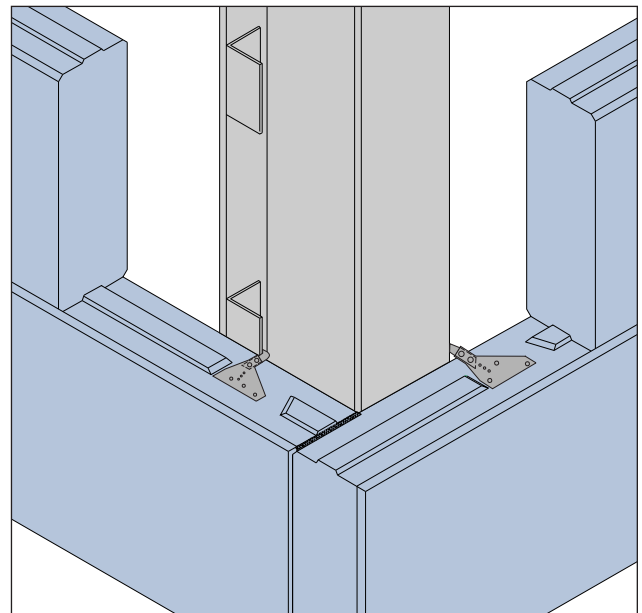
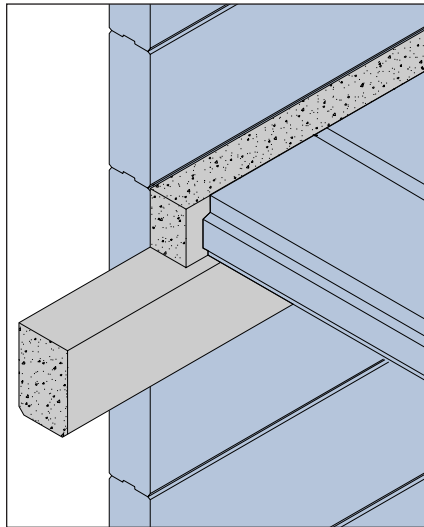

B. Floor Panels

General

There are a number of reasons for choosing autoclaved aerated concrete floors. Consider the low weight, for instance. This influences the size and weight of the foundation, since a traditional floor weighs three times as much as its AERCON counterpart.

The fire-resistant characteristics for AERCON are exceptional.

Also, the AERCON floor panels have superior sound and thermal characteristics inherent to AERCON material.

Another distinct advantage of using AERCON floor panels is the speed of installation. A floor area up to 40 ft² is easily installed with one crane lift utilizing a well-trained erection crew.

Fabrication

Floor panels are supplied on the basis of Strength Class AC4 and AC6. The maximum panel length is 20'-0". The standard panel width is 2'-0". A nominal panel thickness of 8", 10" or 12" is available depending on the loading and span requirements.



Reinforcing is placed in key joints between panels for continuity and diaphragm performance.

Panel System

Floor panels are tailor made. Their length, thickness and reinforcement are determined based on the building requirements and specifications. The standard panel width is 2'-0". See the Overview Section for panel profile information.

Panel Cutting and Openings

All panels may be cut and may contain openings throughout the panel. However, the size, location and type of cut or opening should be coordinated with AERCON prior to the design phase to avoid any unnecessary field modifications.

The reason for this is that every opening, notch or cut (round, rectangular, diagonal) causes additional stress on the area around the potential cut. Any additional reinforcement requirements can be taken into account during the design and fabrication process.

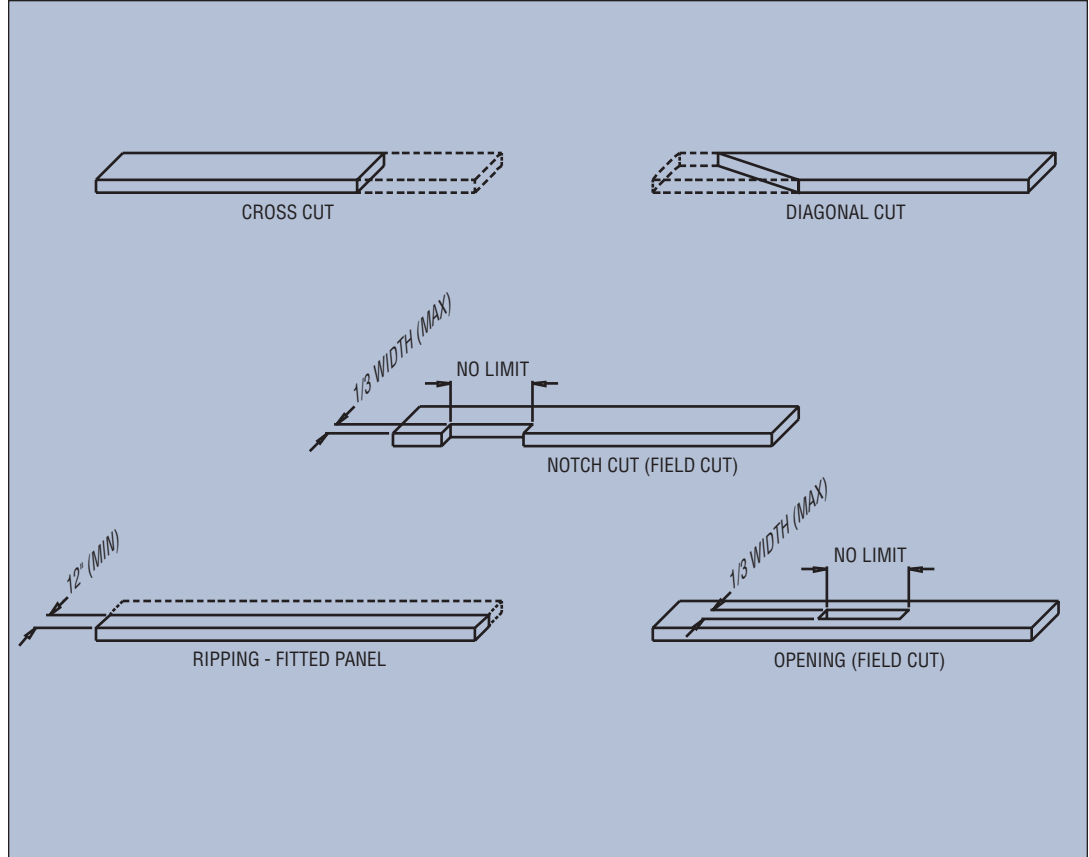

Panel Thickness

The thickness of AERCON floor panels depends on the required span and loads.

The following typical loads may be used for calculating the panel thickness. However, all panels are designed based on the project requirements, as specified by the Design Professional.

◇ Weight of the floor panel

- 39 pcf for AC4
- 49 pcf for AC6

◇ Dead Loads

- Flooring 5 psf
- Ceiling/Mech. 10 psf
- Partition 20 psf

◇ Live Loads

- 40 psf for residential
- 50 psf for offices
- 80 psf for corridors
- 100 psf for egress

For non-standard loads and related questions, consult an AERCON Representative. Check all local jurisdictional requirements for any additional or differing required design loads.

The graph below shows representative spans for a range of live loads. This graph may be used for the preliminary determination of the thickness required for a particular project. Since floor panels are uniquely designed for a project,

the maximum span for an individual panel may deviate from the graphical value.

Deflection

The allowable deflection of AERCON floor panels, due to the total load, is L/240. The allowable deflection for the live load is L/360.

Support

The length of bearing required for AERCON floor panels is 2 1/2" minimum.

Grouting

The key joints at adjacent panels are filled with cement grout in order to provide a positive diaphragm shear transfer.

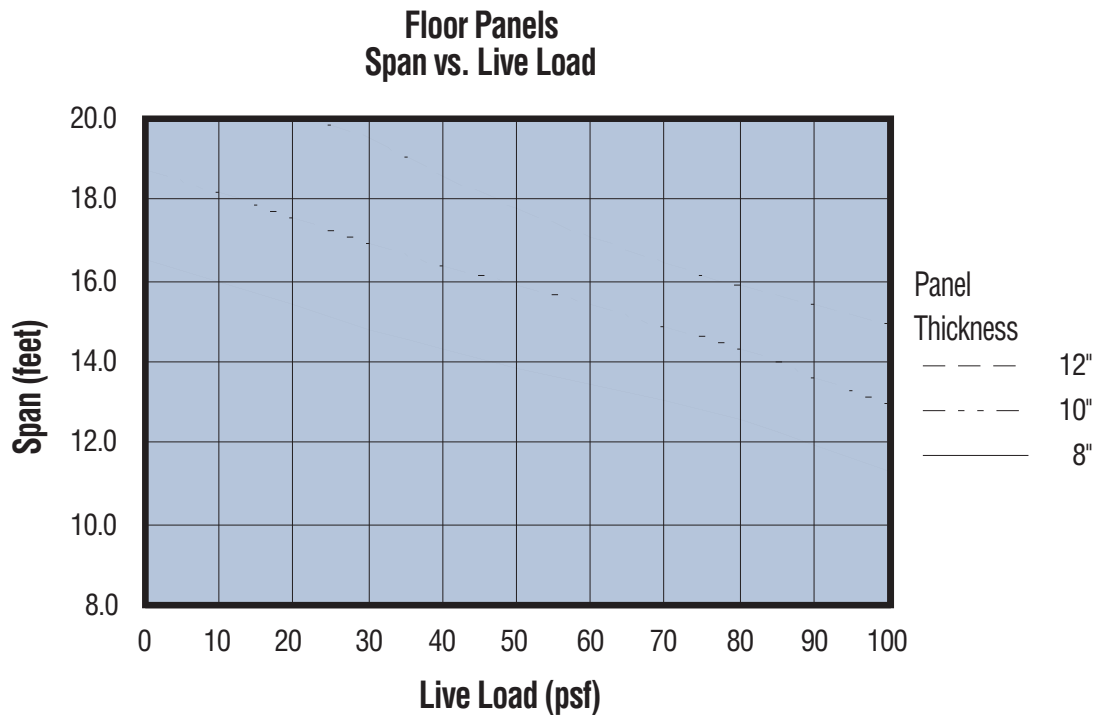

C. Roof Panels

General

To further enhance a building's room climate, acoustic performance and thermal performance, an AERCON roof panel system is the best solution to attain all of these characteristics. AERCON roof panels can be installed on a slope or horizontal. The thermal effects, within the building, from the summer and winter temperatures are minimized. Similar to AERCON floor panels, AERCON roof panels

weigh less than other concrete roof systems. Therefore, a reduction in the size and weight of the building foundation system may be possible.

Another distinct advantage of using AERCON roof panels is the speed of installation. A roof area up to 40 ft² is easily installed with one crane lift utilizing a well-trained erection crew. The fire-resistant characteristics for AERCON are exceptional.

Fabrication

Roof panels are supplied on the basis of Strength Class AC4 and AC6. The maximum panel length is 20'-0". The standard panel width is 2'-0". A nominal panel thickness of 8", 10" or 12" is available depending on the loading and span requirements.

Horizontal (flat) roof panel installation.



Panel System

Roof panels are tailor made. Their length, thickness and reinforcement are determined based on the building requirements and specifications. The standard panel width is 2'-0". See the Overview Section for panel profile information.

Panel Cutting and Openings

All panels may be cut and may contain openings throughout the panel. However, the size, location and type of cut or opening should be coordinated with AERCON prior to the design phase to avoid any unnecessary field modifica-

tions. The reason for this is that every opening, notch or cut (round, rectangular, diagonal) causes additional stress on the area around the potential cut. Any additional reinforcement requirements can be taken into account during the design and fabrication process.

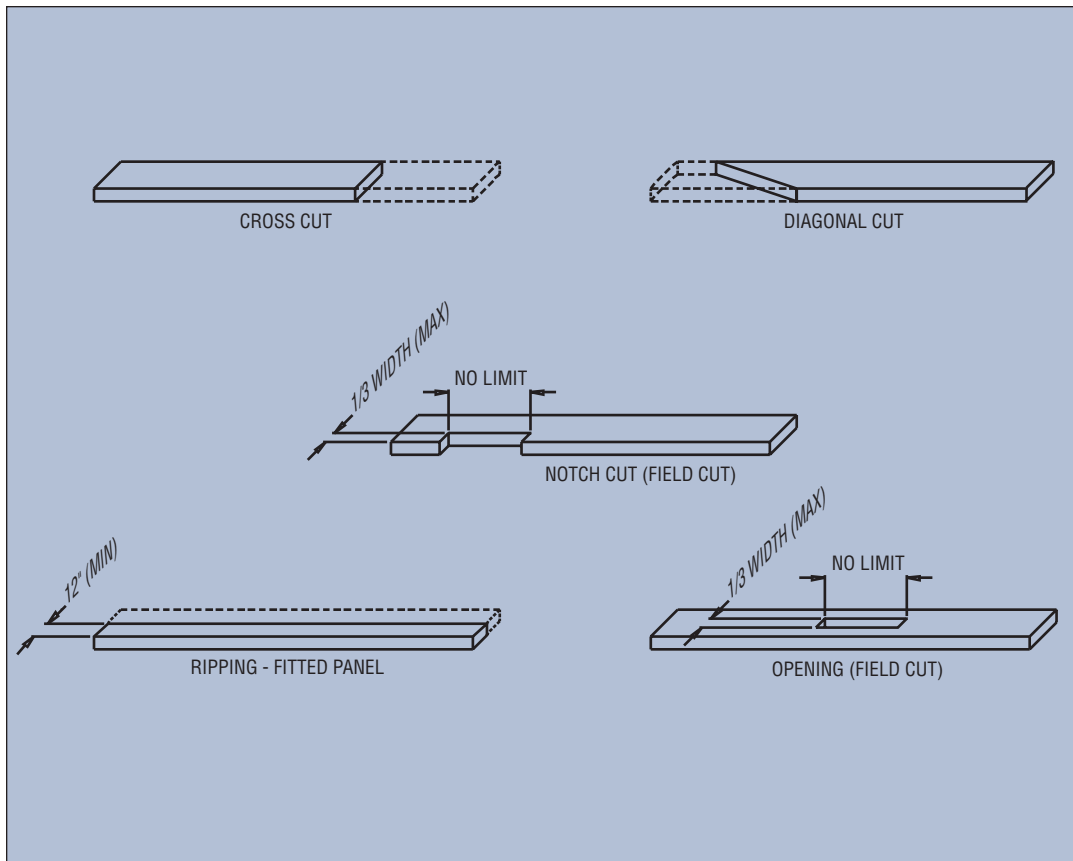

Panel Thickness

The thickness of AERCON roof panels depends on the required span and loads.

Also, the panel thickness may be influenced by the thermal or acoustical insulation requirements in conjunction with the required dead and live loads.

The following typical loads may be used for calculating the panel thickness. However, all panels are designed based on the project requirements, as specified by the Design Professional.

◇ Weight of the roof panel

- 39 pcf for AC4
- 49 pcf for AC6

◇ Dead Loads

- Roofing 15 psf
- Ceiling/Mech. 10 psf

◇ Live Loads

- Roof 20 psf

For non-standard loads and related questions, consult an AERCON Representative. Check all local jurisdictional requirements for any additional or differing required design loads.

The graph below shows representative spans for a range of live loads. This graph may be used for the preliminary determination of the thickness required for a particular project. Since roof panels are uniquely designed for a project, the maximum span for an individual panel may deviate from the graphical value.

**Roof Panels
Span vs. Live Load**

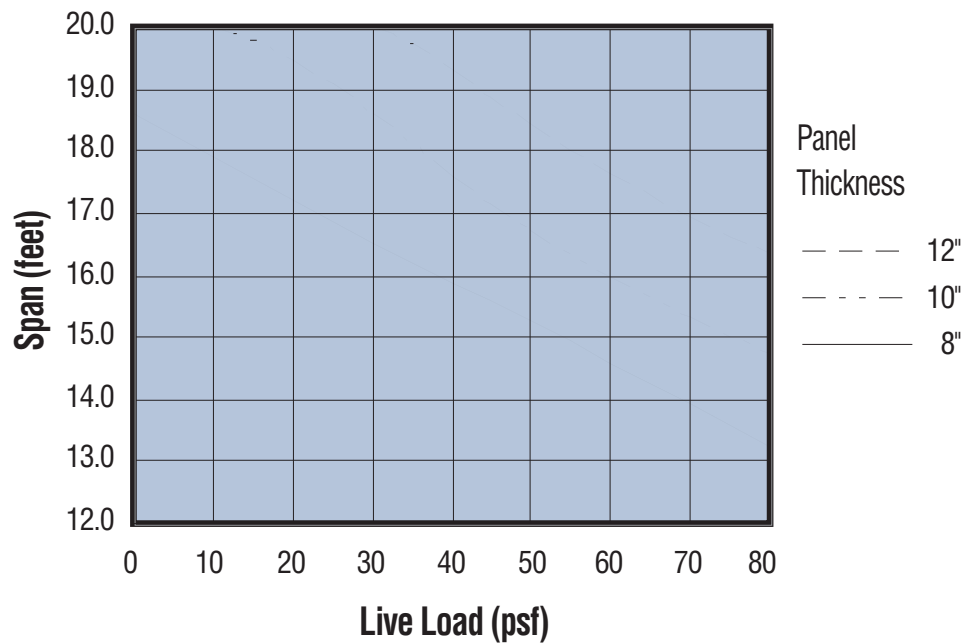

Deflection

The allowable deflection of AERCON roof panels, due to the total load, is $L/180$. The allowable deflection for the live load is $L/240$.

Support

The length of bearing required for AERCON roof panels is $2\frac{1}{2}$ " minimum.

Grouting

The key joints at adjacent panels are filled with cement grout in order to provide a positive diaphragm shear transfer.

Roof Shapes

Traditional flat or sloped roofs are possible with AERCON roof panels. The roof slope for drainage can be achieved by sloping the support framing of the underlying structure or by providing a layer of tapered insulation (the traditional method) on the roof panels.

Sloped roof panel installation.



D. Diaphragm Analysis

AERCON floor and roof panels create structural diaphragms that can be designed to resist lateral loads due to wind or earthquake. The panel system, as a diaphragm, acts as a large, horizontal, deep beam element, spanning the length and width of the structure.

Each diaphragm is securely attached to the lateral load resisting system so that the forces developed within the diaphragm, both normal and parallel to the resisting system, can be properly transferred. This attachment is accomplished through shear friction, mechanical fasteners, shear studs and/or by doweling reinforcing steel into the formed

and poured bond beam around the perimeter of the diaphragm as required.

The design of the roof and floor diaphragms begins by determining the lateral loads on the structure which are transferred to each diaphragm. These forces are derived from the applicable building code. Once these forces are derived for both major directions of the structure, they are applied to the diaphragms which are then analyzed in a manner similar to a horizontal beam on simple supports.

For distribution of forces to the lateral load resisting system, the diaphragm is normally

considered infinitely rigid. The forces are distributed to the lateral load resisting system in proportion to the stiffness of the elements comprising the resisting system. However, the diaphragm design is normally based upon the principle of a flexible diaphragm (beam) on rigid supports.

In the accompanying design example, the lateral loads and associated calculations are shown for the direction parallel to the direction of the roof panels. The same procedure would then also be required for the orthogonal direction.

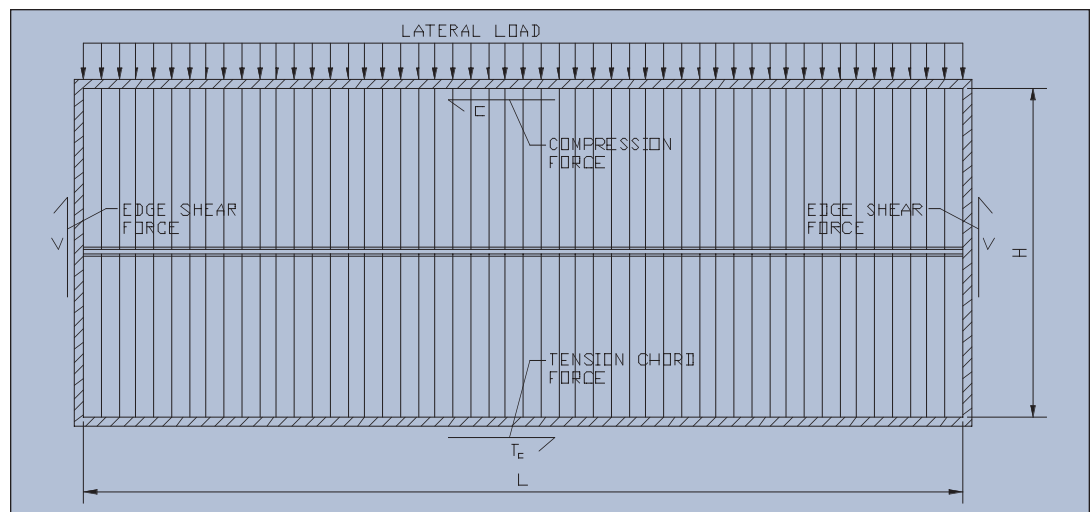

By observation, the critical location for in-plane shear transfer within the diaphragm is between the first and second panels at either end of the structure, since this is the location for the maximum shear at a diaphragm joint. This shear force is transferred between panels by means of the grout key. The maximum shear developed within the grout key is checked against the allowable shear value of the panel.

The diaphragm analysis begins by determining the maximum moment within the diaphragm using traditional beam formulas. The resultant tensile stress due to this moment is checked against the allowable tensile stress in the reinforcing within the bond beam. This is accomplished by first dividing the maximum moment developed within the diaphragm by the "depth" of the diaphragm (i.e. its horizontal dimension) to determine the resultant tensile chord force. The resultant tensile stress in the perimeter bond beam reinforcing is determined by dividing the tensile chord force by the area of reinforcing furnished. The resultant compressive stress in the panels is checked against the allowable flexural compressive stress. The resultant compressive stress is determined by dividing the maximum moment by the section modulus of the diaphragm. The chord force of the diaphragm is transferred from the panels to the bond beam based on the

adhesion between the two elements. The shear stress at the panel/bond beam interface is checked based upon the allowable shear stress in the panels and the available shear area. This shear development transfer is considered to occur along one half of the length (L).

Finally, the shear force along each short edge of the diaphragm is transferred from the panels to the bond beam based on the adhesion between the two elements.

The shear stress at the panel/bond beam interface is checked based upon the allowable shear stress of the panels and the available shear area. This shear transfer is considered to occur uniformly for the entire depth (H) of the diaphragm.

If the actual shear stress exceeds the allowable shear stress, shear-friction reinforcement theory can be utilized to provide the required shear transfer.

This same procedure is then repeated with the loads transferred to the diaphragm for any other major direction.

When the diaphragm consists of multiple 'strips' of panels, such as the two panel 'strips' of the design example, the shear across the joint between panel 'strips', resisted by the reinforcing steel, must be checked.

A continuity connection between the panels and the bond beam is accomplished by means of reinforcing bars from the panel joints into the bond beam.

FORMULAS:

Tensile chord force (T_c):

$$T_c = \frac{M}{jH}$$

where M is the design moment of the diaphragm, 'j' is taken as unity (1.0), and 'H' is the depth of the diaphragm.

Allowable shear for a grouted joint or concrete bond beam (V_g):

$$V_g = F_v(a)$$

where F_v is the allowable shear stress in the AAC and 'a' is the height of the grout filled key joint or thickness (vertical dimension) of panel/bond beam, depending on the contact height. Dimensions for the key joint are given in the detail at the end of this subsection.

Area of shear reinforcement (A_{vf}):

$$A_{vf} = \frac{V_u}{\mu F_s}$$

where ' V_u ' is the design shear force, ' μ ' is the coefficient of friction equal to 0.45, and F_s is the allowable tensile stress in the reinforcement.

EXAMPLE:

A single story building, 40 feet wide by 100 feet long, is subjected to wind that results in the loads shown being induced onto the roof diaphragm of the building. The diaphragm is surrounded by a perimeter concrete bond beam with two #4, Grade 60 reinforcing bars. The roof diaphragm panels are Strength Class AC4, nominal 8" thick by 2 feet wide. Determine the adequacy of the diaphragm to resist the imposed loads. See Properties Table in the Overview Section for allowable stress values. Allowable stresses can be increased by one-third since the load combination includes wind.

Allowable shear stress in AERCON reinforced panels = 15 psi

Allowable flexural compressive stress in AERCON reinforced panels = 193 psi

First consider the wind loads applied to the long walls.

Check the shear at the critical location for in-plane shear transfer within the diaphragm, which is between the first and second panels. The grout filled key joint between adjacent panels transfers the shear. The shear stress in the AERCON panels controls the joint strength.

$$V = 9,978 \text{ lbs} - 2 \text{ ft} (276 \text{ plf}) = 9,426 \text{ lbs}$$

$$V_g = F_v(a) = [(15 \text{ psi}) (1.333)] (2.79 \text{ in}) (12 \text{ in/ft}) = 669 \text{ plf} > 9426 \text{ lbs} / 40 \text{ ft} = 236 \text{ plf} \quad \text{so grouted key joint is OK}$$

$$\text{Tensile Chord Force: } T_c = \frac{M}{j H} = \frac{234.2 \text{ ft-k}}{(1.0) 40 \text{ ft}} = 5.86 \text{ kips}$$

Check tensile chord stress in bond beam reinforcing bars and flexural compressive stress in the panels:

$$f_s = \frac{T_c}{A_s} = \frac{5.86 \text{ kips} (1,000 \text{ lbs/kip})}{2 (0.20 \text{ in}^2)} = 14,650 \text{ psi}$$

$$F_s = 24,000 \text{ psi} (1.333) = 32,000 \text{ psi} > 14,650 \text{ psi} \quad \text{so (2) #4 bars are OK}$$

$$f_b = \frac{M}{S} = \frac{234.2 \text{ ft-k} (1,000 \text{ lbs/kip})}{\frac{(0.66 \text{ ft}) (40 \text{ ft})^2}{6}} = 1,331 \text{ lbs/ft}^2 = 9.2 \text{ psi}$$

$$F_b = 193 \text{ psi} (1.333) = 257 \text{ psi} > 9.2 \text{ psi} \quad \text{so AERCON compressive stress is OK}$$

Shear (chord force) is developed along one half of the diaphragm length.

$$v = \frac{5.86 \text{ kips} (1,000 \text{ lbs/kip})}{(1/2) 100 \text{ ft}} = 117 \text{ plf}$$

$$V_{AAC} = [(15 \text{ psi}) (1.333)] (7.874 \text{ in}) (12 \text{ in/ft}) = 1889 \text{ plf} > 117 \text{ plf} \quad \text{so shear between panel and bond beam is OK}$$

Shear along each short edge is developed uniformly along the diaphragm depth.

$$v = \frac{9978 \text{ lbs}}{40 \text{ ft}} = 249 \text{ plf}$$

$$V_{AAC} = [(15 \text{ psi}) (1.333)] (7.874 \text{ in}) (12 \text{ in/ft}) = 1889 \text{ plf} > 249 \text{ plf} \quad \text{so shear between panel and bond beam is OK}$$

Diaphragm Details

- 1 AERCON Block
- 2 AERCON Floor/Roof Panel
- 3 AERCON Compatible Coating w/Mesh at Discontinuities
- 4 AERCON Block Parapet Wall
- 5 Roof System
- 6 Dowel (Drill and Epoxy as Required)
- 7 2 Layers of Felt Paper
- 8 Reinforcing Bar in Grout Filled Key Joint
- 9 Parapet Flashing
- 10 Bond Beam w/ Reinforcing Bars
- 11 3/8" ± Mortar Bed
- 12 Gypsum Board
- 13 AERCON Interior Wall Plaster or Gypsum Board

Typical Grout Filled Key

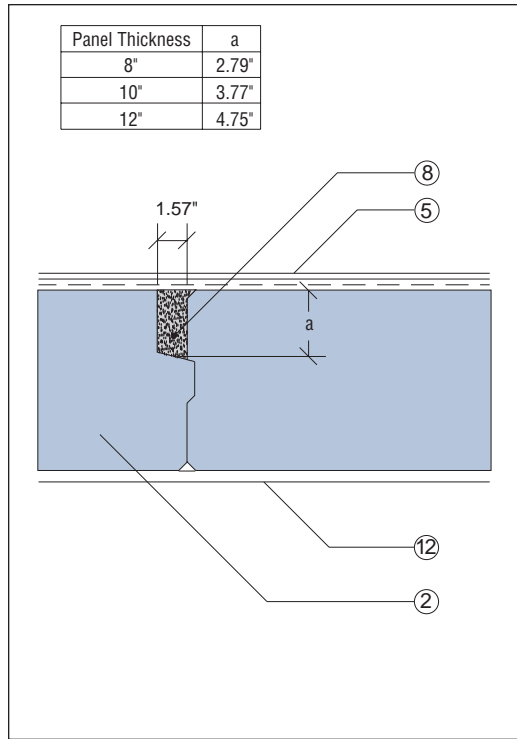

Panel Bearing on Interior Support

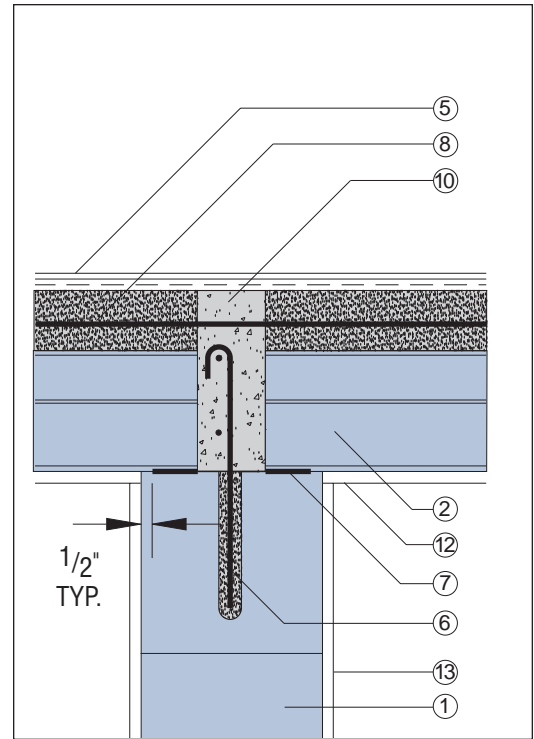

Perpendicular Panel at Bearing Wall

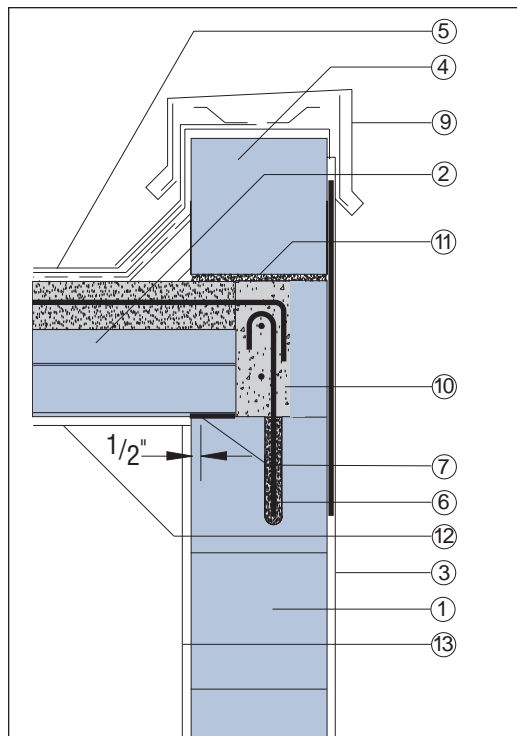

Parallel Panel at Wall

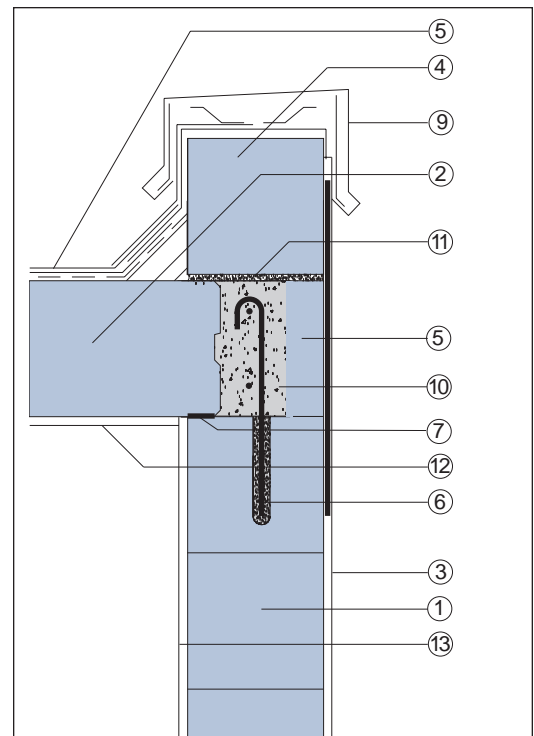

E. Non-Load Bearing Wall Panels

General

Exterior walls primarily determine the efficiency of maintaining the overall climate in the workplace during the cold winter and hot summer months. The use of AERCON wall panels is a logical choice for use with industrial and commercial buildings.

For legitimate consideration within the construction market, the wall panels must be erected quickly and efficiently while maintaining a high standard of in-place quality. When these

installation factors are achieved, the end result translates into economy.

AERCON has addressed these issues by supplying a technologically advanced product to the commercial building market. A building, the design of which has been coordinated using AERCON products, can be constructed to attain minimized effort and expense. A building so designed will then contain one of the finest sound and thermal insulation materi-

als available in today's market. The acoustic ambiance associated with AERCON materials provides the highest quality room environment.

The capabilities of wall panels are not confined to exterior walls only. The wall panels can easily be used for non-load bearing interior walls and fire walls. All of these applications, which are already being used around the world, can also be utilized in the United States. The possibilities are unlimited.



AERCON non-load bearing vertical wall panels connected to a steel frame structure.

Fabrication

Wall panels are supplied on the basis of Strength Class AC4 and AC6. The maximum panel length is 20'-0". The standard panel height/width is 2'-0". A nominal panel thickness of 8", 10" or 12" is available depending on the design loads and span requirements.

Panel Cutting and Openings

All panels may be cut at various angles and may contain openings throughout the panel. However, the size, location and type of cut or opening should be coordinated with AERCON prior to the design phase to avoid any unnecessary field modifications. The reason for

this is that every opening, notch or cut (round, rectangular, diagonal) causes additional stress on the area around the potential cut. Any additional reinforcement requirements can be taken into account during the design and fabrication process.

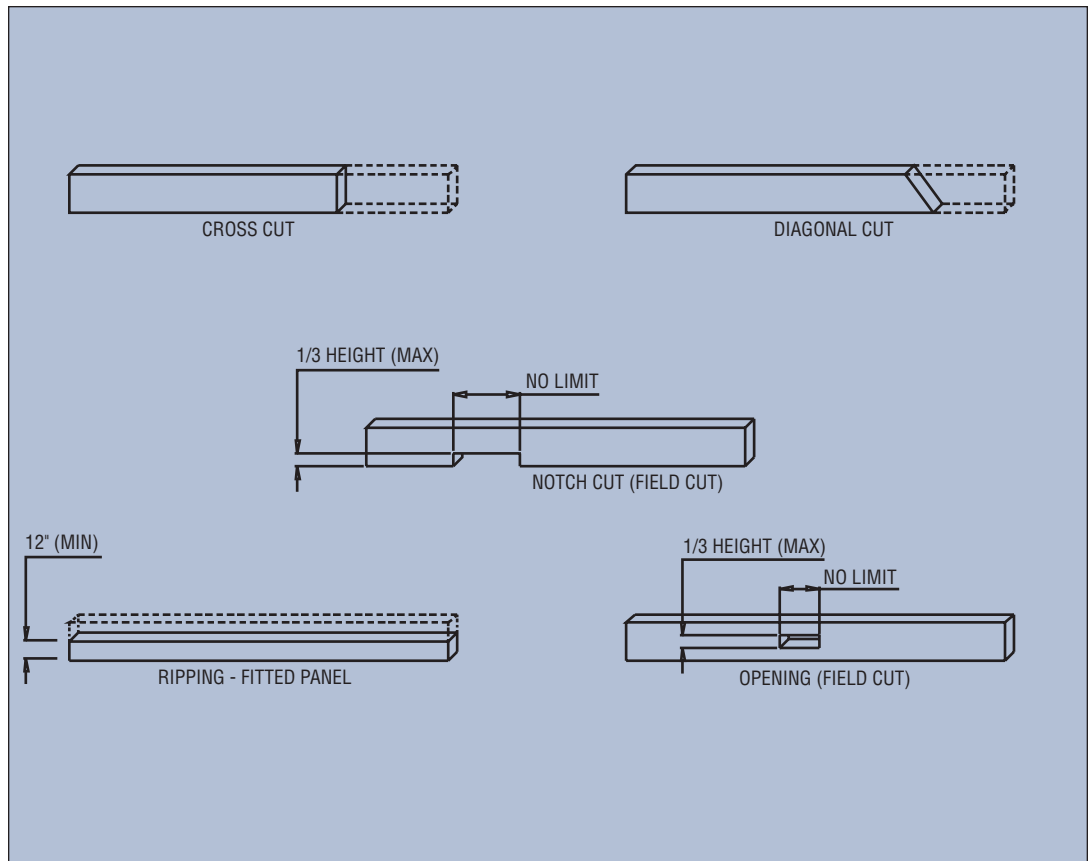

Panel System

Working with a 2'-0" standard panel width can lead to construction efficiency. The standard panel should be coordinated and adjusted for a building elevation that contains a strip of windows or other façade interruptions.

Panel Thickness

There are a number of factors that determine the thickness of an AERCON wall. In addition to any requirements that are established for acoustical and thermal insulation, the lateral loads directly affect the design. In most cases, an 8" thick wall panel is sufficient to resist the design loads.

Wall Heights

The height for AERCON horizontal wall panels is unlimited. Special provisions for construction limitations in high rise applications are required as shown.

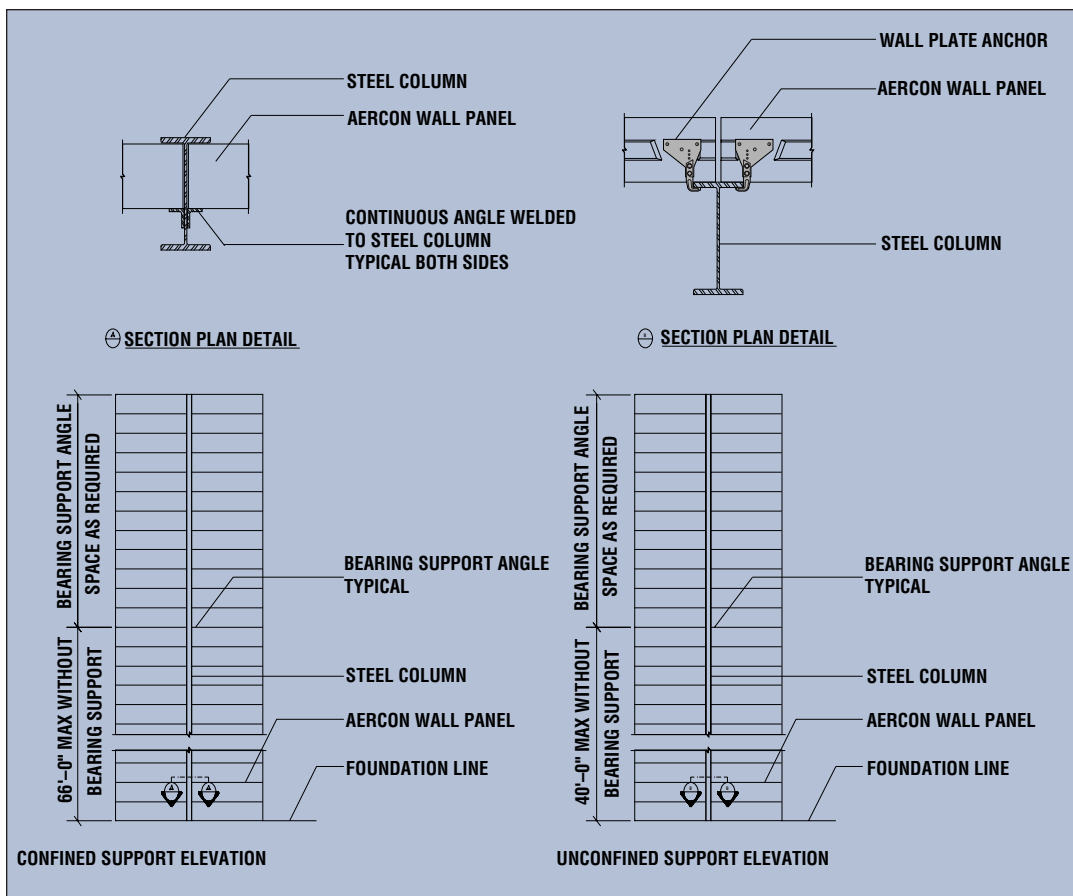

Wall Anchors

Wall anchors should be specified by the Design Professional based on the project specifications. Typical plates and connection details are shown in the Construction Details Section.

Deflection

The allowable lateral deflection of AERCON wall panels due to lateral load is L/240.

Lateral Support

For AERCON wall panels, the required minimum bearing length for resistance to lateral loads is 1½”.

Supports for Panel Weight

When designing a support for the self-weight resulting from an individual panel or multiple stacked panels, the contact area between a panel and its

support must result in a bearing stress that does not exceed the allowable values as shown in the table below. The minimum bearing dimension in any direction is 4”.

Bearing Stress Condition	Strength Class	
	AC4	AC6
Allowable Bearing Stress without a Bearing Pad	60 psi	85 psi
Allowable Bearing Stress with a Bearing Pad	100 psi	130 psi

**Wall Panels
Span vs. Wind Load**

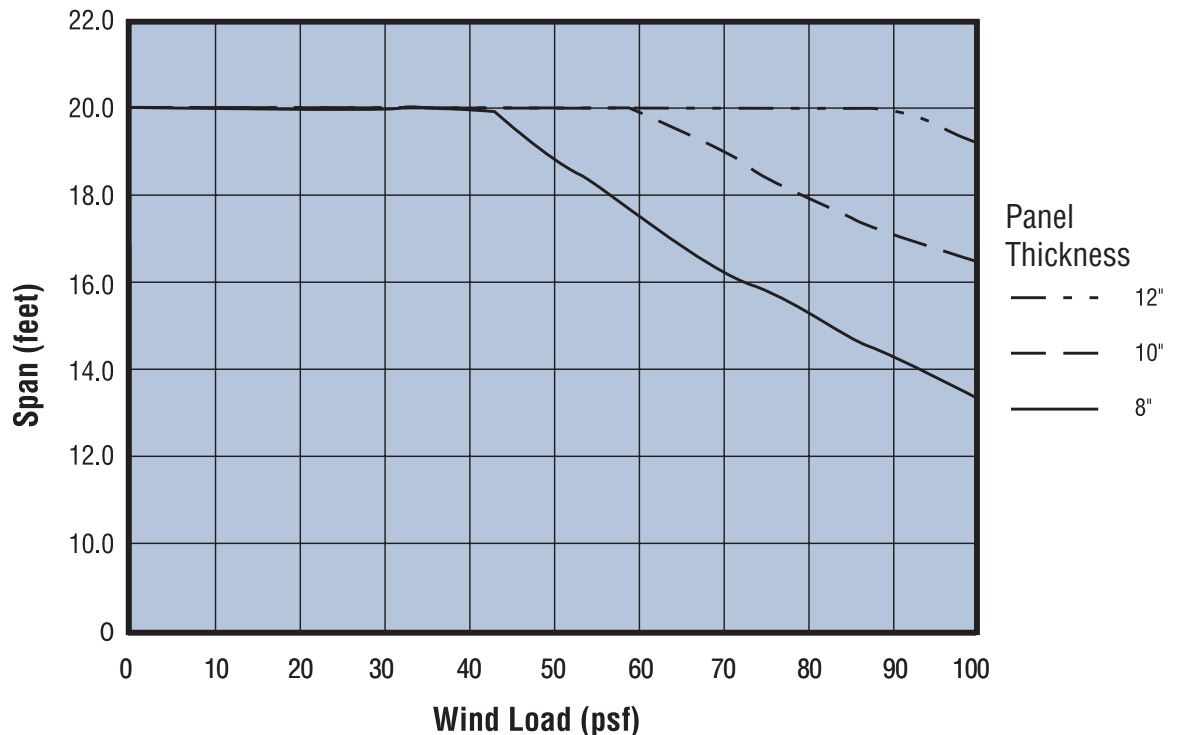

Design of Wall Panel Connections

A key aspect of AERCON non-load bearing wall panel systems is the connection between a panel and the superstructure. For most situations, a wall plate anchor connection is used. Wall plate anchors and other connection types, as shown in the Construction Details Section, are designed to

transfer lateral loads from a wall panel to the supporting structure. The design of these connections is relatively simple. The following design example and available connection types will enable the Design Professional to specify the appropriate connection at each desired location within the wall panel system. The rated capacity of the wall plate

anchors is a function of the AAC Strength Class. While AC4 and AC6 are the typical manufactured Strength Classes, wall panels may be specified as AC3.3 or AC4.4 to coincide with the published capacity values.

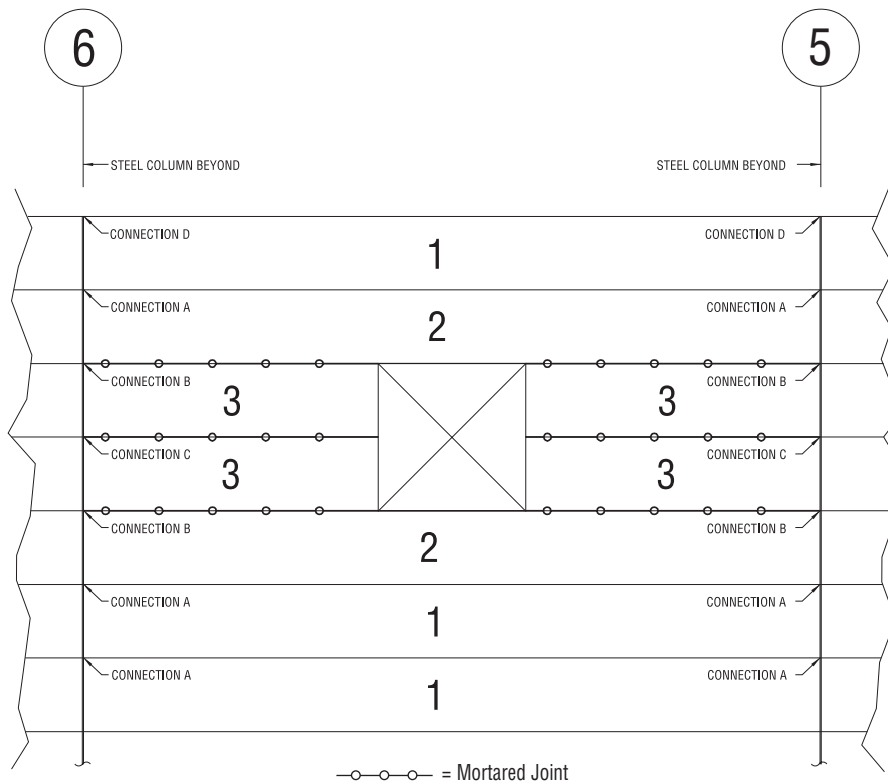

Example

Design Assumptions:

Design Load = 35 psf

Strength Class = AC4.4

Panel Length = 15 ft

(Distance from Grid 5 to 6)

Panel Height = 2 ft each

Panel Thickness = 8 in Nominal

Size of Opening = 4 ft x 4 ft

(Centered in bay)

Connection A

Reaction at Connection A = 35 psf * (1 ft + 1 ft) * 15 ft/2 = 525 lbs based on one-quarter of the gross area of Panel 1 and one-quarter of the gross area of Panel 2.

Use Fixinox Anchor 69 913 or 70 817 (Capacity = 675 lbs) depending on the support arrangement. For the 70 817 style of anchor, to connect two adjacent horizontal panels to the same column, one anchor rail would be required located at the column centerline.

Connection B

Reaction at Connection B = 35 psf * (2 ft + 1 ft) * 15 ft/2 = 787.5 lbs simplistically based on the gross area of one Panel 3, one-quarter of the gross area of the opening, and one-quarter of the gross area of Panel 2.

Use Fixinox Anchor 68 817 or 68 815 (Capacity = 1050 lbs). For these styles of anchor, to connect two adjacent horizontal panels to the same column, two anchor rails would be

required, each shifted relative to the column centerline.

Connection C

The two Panel 3s on each side of the opening are designed based on the panels acting as unreinforced AAC, spanning between the Panel 2 above the opening and the Panel 2 below the opening. Each joint in this area is mortared together to achieve this continuity. Therefore, Connection C is not required for lateral load transfer but is used primarily for erection stability until the mortar has set.

Use Fixinox Anchor 69 913 or 70 817 (Capacity = 675 lbs) to match Connection A style.

Connection D

Reaction at Connection D = 35 psf * (1 ft) * 15 ft/2 = 262.5 lbs based on one-quarter of the gross area of Panel 1.

Use Fixinox Anchor 69 913 or 70 817 (Capacity = 675 lbs).

While it may seem efficient to specify various anchor types based on the required load capacity, the number of anchor types on a project should be minimized in order to facilitate an easier erection process. Inventorying, sorting, finding, and installing only one or two types of anchors is much simpler than handling four or five types.

F. Load Bearing Vertical Wall Panels

General

AERCON load bearing vertical (ALV) wall panels can be utilized to create a building whose primary structural system is comprised exclusively of AERCON reinforced panels. ALV wall panels are the mechanism for supporting gravity loads while also functioning as the lateral load resisting system. Using ALV wall panels produces a cost effective, load bearing, modular system with rapid installation while providing the excellent benefits

associated with all AERCON building materials.

Panel System

The use of modular 2 feet wide panels, along with half-panel widths of 1 foot where necessary, creates the repetition and efficiency that leads to an economical installation. The panel thickness and story height vary depending on the design requirements and constraints of the project. ALV wall panels are supplied on the basis of Strength Class AC4 and AC6.

Available thicknesses are nominal 8", 10" and 12". Standard panel heights of 8'-0", 9'-4" and 10'-0" are available. Special story heights, up to a maximum of 12'-0", are available upon request.



Hotel being constructed of AERCON load bearing vertical wall panels.

Design Flexibility

In order for a building system to be advantageous for architects, engineers and builders alike, there must be design flexibility. The ALV wall panel system provides that flexibility. With minimal design modifications, the standard panel can be used to accommodate the constraints of a building while maintaining the panel optimization and cost effectiveness of the overall system. Also, the versatility of this system is demonstrated at window and door openings where the panels can be adjusted for accurate constructed rough openings.

Reinforcement

The simplicity of the ALV wall panel system is that the panels are load bearing and internally reinforced. The reinforcing for ALV wall panels can be designed to withstand the extremely high wind loads associated with hurricanes and coastal regions.

Installation

The ease and speed of construction are attained through many factors inherent in the

ALV wall panel system. For example, a traditional bond beam at each level is not required along the perimeter of the building as in masonry construction. Instead, when AERCON floor or roof panels are used, the integral diaphragm bond beam provides the required perimeter continuity; or a tension strap can be used when non-panel floor or roof systems are utilized. The diaphragm bond beam or tension strap is placed at the top of the wall panels along the perimeter of the building. Whichever element is used acts as a tension chord for the transfer of diaphragm loads and provides overall stability and continuity for the building structure.

In addition to the elimination of the traditional bond beam, the transfer of wind uplift and lateral loads can be achieved by using a dowel into the diaphragm bond beam (when AERCON floor or roof panels are used) and a strap anchor embedded in the foundation when uplift exists at the foundation level. The reinforcing

dowel is installed at the top of the panel by drilling and epoxying. When a truss roof system is specified, a strap anchor can be used to secure each truss directly to a wall panel. Also, a strap anchor is embedded in the foundation when uplift exists at that level. Whether panels or trusses are used, the uplift is transferred through the longitudinal reinforcing bars in the panels. When strap anchors are used, they are connected to a wall panel using tube nails, easily installed using a regular hammer.

Applications

ALV wall panels are extremely versatile and allow enormous design flexibility. Since this system represents an economical alternative to other building systems, it may be used in a variety of applications. For example, production homes, multifamily, office, retail and low rise hotel construction would be well suited for ALV wall panels. The system offers economy, structural integrity, rapid construction, and of course, the extensive benefits of AERCON building materials.

AERCON load bearing vertical wall panels are multifunctional structural elements which must be designed for various conditions, including but not limited to:

- Vertical Loads – Design based on the AAC material properties of the panel, neglecting internal reinforcement. See the Blocks subsection for suggested design method.

- Diaphragm Bond Beam Design - See Diaphragm Analysis subsection for suggested design method.
- Lateral Loads – AERCON determines the appropriate internal reinforcement in panels that resist out-of-plane lateral loads normal to their surface.
- Shear Wall Analysis - See below for a suggested design method.

Panel Wall System Shear Wall Analysis:

The following procedure determines the allowable in-plane load for a series of ALV wall panels mortared together and used as a shear wall. The in-plane load is balanced by 85% of the sum of the wall dead load plus superimposed dead loads on the top of the wall.

FORMULAS:

L = total shear wall length, ft

P_v = allowable in-plane force at the top of the shear wall, lb

F = actual in-plane force at the top of the shear wall, lb

h = panel height, ft

D = dead load of shear wall due to self-weight, lb

γ_D = design dead weight of wall panels, pcf (See Properties Table in the Overview Section.)

t = panel thickness, in

w = superimposed dead load along the top of the shear wall, plf

M_r = resisting moment of shear wall based on dead load, ft-lb

M_{OTM} = overturning moment for shear wall design, ft-lb

T = tension force used to resist overturning of the shear wall, lb

R = 0.85, dead load reduction factor

To establish the maximum value of shear force that can be applied at the top of the shear wall, set

$$[M_{OTM} = (P_v)(h)] = (R)(M_r).$$

$$M_r = \frac{D L}{2} + \frac{w L^2}{2} \quad \text{where} \quad D = \frac{h L t \gamma_D}{12}$$

$$\text{so } M_r = \frac{h L^2 t \gamma_D}{24} + \frac{w L^2}{2}$$

$$(P_v)(h) = R \left(\frac{h L^2 t \gamma_D}{24} + \frac{w L^2}{2} \right)$$

$$\text{Solving for } P_v: \quad P_v = \frac{L^2 (h t \gamma_D + 12 w)}{28.24 h}$$

If the allowable in-plane force (P_v) at the top of the shear wall is less than the actual in-plane force (F) at the top of the shear wall, then the net tension force (T) in the end of the shear wall will require that a tension strap or tie-down be installed into the foundation. The tension force (T) is determined by the following equation.

$$T = \frac{28.24 F h - L^2 (h t \gamma_D + 12 w)}{28.24 L}$$

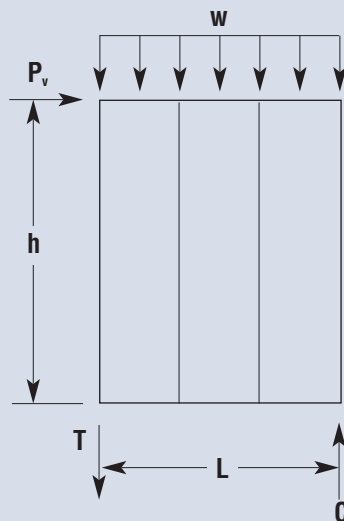

G. Blocks and Lintels

Structural Components

The following parts of this subsection show by examples and charts the methods for designing:

- axially loaded bearing walls
- walls subjected to lateral wind loads
- bond beams subjected to uplift

- shear walls
- lintels

all utilizing AERCON standard block, ValuBlock and U-block.

The design methods presented are for single story construction, but are also applicable to multi-story construction.

For additional applications with other AERCON building systems, please consult an AERCON Representative.

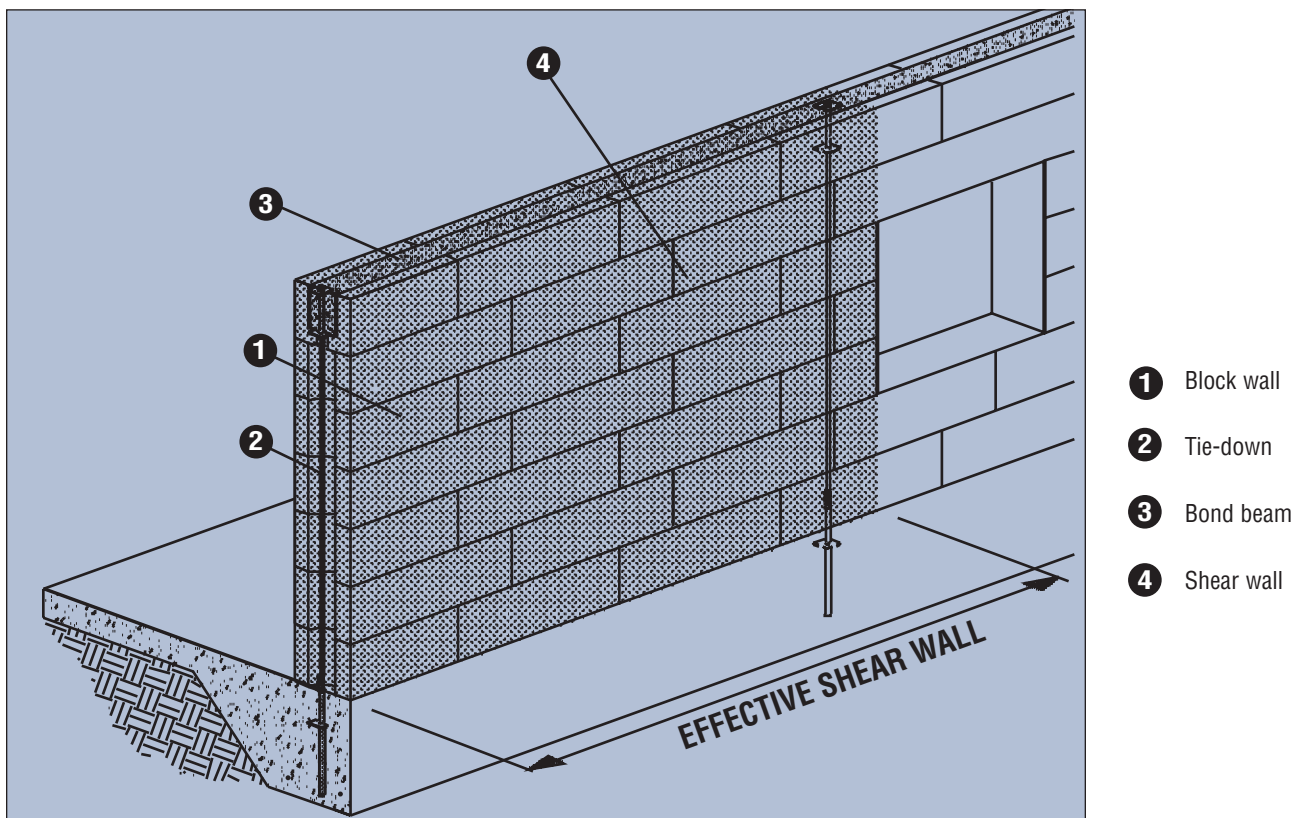

Allowable Vertical Loads

AERCON block walls are solid walls that provide excellent load carrying capacity for axial loads. The solid block provides a full bed surface area for AERCON mortar.

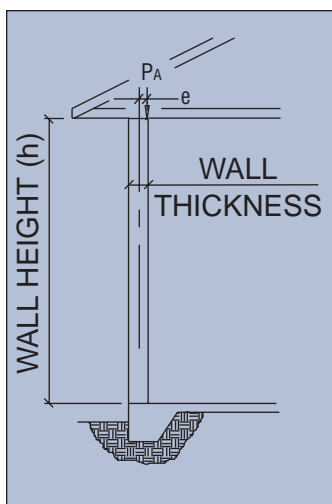

f'_{AAC} = minimum specified compressive strength, psi

F_a = allowable axial compressive stress, psi

F_b = allowable flexural compressive stress, psi

F_t = allowable flexural tensile stress, psi

A = bed area of the wall per linear ft, in² per ft

S = section modulus of the wall per linear ft, in³ per ft

h = effective height of wall, ft

D = dead load (weight) of the wall at the bottom, pounds

P_a = actual axial superimposed load, pounds

e = resultant eccentricity of the superimposed load, inches

Formulas:

The superimposed eccentric axial load is applied at the top of the wall. The dead weight of the total wall height is calculated and added to the total superimposed load to determine the total axial design load. The allowable axial compressive stress is calculated based on the slenderness ratio. The allowable flexural compressive stress is then calculated. The actual axial compressive stress (f_a) and the actual flexural compressive stress (f_b) are derived in terms of the geometric characteristics of the AERCON wall. All of these values are substituted into the unity equation and the allowable superimposed axial load at the resultant eccentricity is solved for. The maximum axial load at the resultant eccentricity is also calculated based upon the allowable flexural tensile stress. The maximum axial load at the resultant eccentricity is then the smaller of the values calculated using either the unity equation or the allowable flexural tensile stress.

Allowable axial compressive stress (F_a):

$$F_a = \frac{f'_{AAC}}{4} \left[1 - \left(\frac{12h}{140r} \right)^2 \right]$$

for $h/r \leq 99$

Allowable flexural compressive stress (F_b):

$$F_b = \frac{f'_{AAC}}{3}$$

Unity equation:

$$\frac{f_a}{F_a} + \frac{f_b}{F_b} \leq 1.0$$

Allowable superimposed axial load at the resultant eccentricity (P_{ac}), compressive stress controlling:

$$P_{ac} = \frac{F_a F_b A S - D S F_b}{S F_b + A F_a e}$$

Allowable superimposed axial load at the resultant eccentricity (P_{at}), flexural tensile stress controlling:

$$P_{at} = \frac{F_t}{\frac{e}{S} - \frac{1}{A}}$$

EXAMPLE:

An unreinforced, nominal 8" thick AERCON block wall, Strength Class AC4, eight feet high, is subjected to an axial load at the top of the wall at an eccentricity of one inch. Determine the maximum axial load, at the one inch of eccentricity, that the wall can carry in pounds per linear foot. Reference the Overview Section for compressive strength, allowable flexural tensile stress, design dead weight and actual thickness.

Wall height (h) = 8' - 0", including bond beam height of 8 in

Superimposed load eccentricity (e) = 1 in

Wall thickness (b) = 8 in nominal (actual = 7.874 in) with a design dead weight of 37 pcf

Wall area per foot of length (A) = 7.874 in x 12 in = 94.5 in² per ft

Wall section modulus per foot of length (S) = $\frac{(7.874 \text{ in})^2 \times 12 \text{ in}}{6} = 124 \text{ in}^3 \text{ per ft}$

Wall moment of inertia per foot of length = $\frac{(7.874 \text{ in})^3 \times 12 \text{ in}}{12} = 488 \text{ in}^4 \text{ per ft}$

Radius of gyration (r) = $(488 \text{ in}^4 / 94.5 \text{ in}^2)^{1/2} = 2.273 \text{ in}$

Bond beam dead load = 30 plf (see Bond Beams, later in this subsection)

Wall dead load = (8.0 ft - 0.667 ft) (7.874 in / 12) (37 pcf) = 178 plf (excluding bond beam course)

Total wall dead load at base of wall (D) = 30 plf + 178 plf = 208 plf

$$F_a = \frac{f'_{AAC}}{4} \left[1 - \left(\frac{12 h}{140 r} \right)^2 \right] = \frac{580 \text{ psi}}{4} \left[1 - \left(\frac{12 (8 \text{ ft})}{140 (2.273 \text{ in})} \right)^2 \right] = 131.8 \text{ psi}$$

$$F_b = \frac{f'_{AAC}}{3} = \frac{580 \text{ psi}}{3} = 193 \text{ psi}$$

$$P_{ac} = \frac{F_a F_b A S - D S F_b}{S F_b + A F_a e} = \frac{131.8 \text{ psi} (193 \text{ psi}) 94.5 \text{ in}^2 (124.0 \text{ in}^3) - 208 \text{ lbs} (124.0 \text{ in}^3) 193 \text{ psi}}{124.0 \text{ in}^3 (193 \text{ psi}) + 94.5 \text{ in}^2 (131.8 \text{ psi}) 1.0 \text{ in}}$$

$P_{ac} = 8,059 \text{ lbs per foot of wall length}$

$$P_{at} = \frac{F_t}{\frac{e}{S} - \frac{1}{A}} = \frac{24 \text{ psi}}{\frac{1 \text{ in}}{124 \text{ in}^3} - \frac{1}{94.5 \text{ in}^2}} = -9,533 \text{ lbs per foot of wall length}$$

Since P_{at} is negative, the compressive stress controls and the maximum axial load at a one inch eccentricity is 8,059 lbs per foot of wall length.

Wind Loads

AERCON block walls are solid walls that provide excellent resistance to lateral wind loads. Walls built of solid AERCON block are easy to design and construct. The solid block provides a full bed surface area for AERCON mortar and, therefore, a full block sectional area for resisting lateral wind loads which cause out of plane bending. All lateral wind loads are resisted by the flexural capacity of the masonry with the tensile stress governing the design. The tie-down reinforcing through the bond beam, either a threaded rod in a narrow chase or standard reinforcing bars grouted solid in pre-drilled cores, provides all of the resistance to uplift that is required.

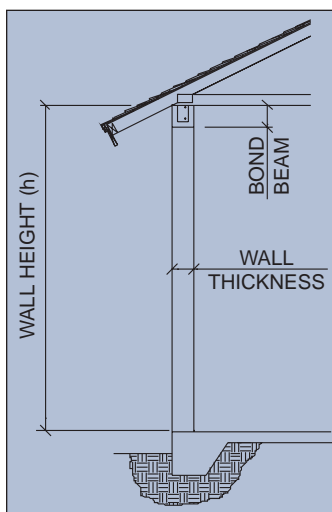

Formulas:

Design assumptions: (1) all uplift is transferred along the bond beam to the vertical tie-down reinforcing; (2) all wind loads are distributed vertically to the bond beam/roof diaphragm and to the floor slab; (3) AERCON units are unreinforced and the allowable flexural tensile stress controls; (4) the wall section is considered uncracked in order to use the flexural tensile method; (5) the top of the wall is considered pinned; and (6) the bottom of the wall is considered as providing some moment resistance.

The maximum moment at the base of the wall is calculated using one-half of the AERCON allowable flexural tensile stress. This value is conservative compared to the allowable stress specified in ACI 530-02. The actual maximum wind load moment is then determined and the actual maximum bending stress is calculated based upon the wall section properties. The actual axial compressive stress due to the dead weight of the upper portion of the wall is determined and then added to the allowable flexural tensile stress, which is increased by

one-third for wind loads, to give the allowable total flexural tensile stress. The actual flexural tensile stress is then compared to the allowable total flexural tensile stress.

w = design velocity pressure, psf

S = section modulus, in³

Allowable flexural tensile stress increased for wind:

$$F_t = 24 \text{ psi (1.333)} = 32 \text{ psi}$$

Maximum moment considered at the base of the wall (M_{base}):

$$M_{\text{base}} = (1/2) F_t S$$

Location of maximum moment (x) within the height of the wall (h):

$$x = \frac{h}{2} + \frac{M_{\text{base}}}{wh}$$

Maximum moment within the height of the wall (M_{max}):

$$M_{\text{max}} = \frac{wh^2}{8} - \frac{M_{\text{base}}}{2} + \frac{M_{\text{base}}^2}{2wh^2}$$

Actual axial compressive stress due to wall weight at height x (f_a):

$$f_a = \frac{\text{wall dead load}}{\text{wall section area}}$$

Actual flexural tensile stress at height x (f_t):

$$f_t = \frac{M_{\text{max}}}{S}$$

Actual shear stress at the bottom of the wall (f_v):

$$f_v = \frac{\text{wind force at bottom of wall}}{\text{wall section area}}$$

EXAMPLE:

An unreinforced, nominal 8" thick AERCON block wall, Strength Class AC4, ten feet high, is subjected to a wind load. Assume that the design velocity pressure is 33 psf, including all applicable gust coefficients in accordance with the governing building code, and that the wall is "pinned" at the roof diaphragm and has a defined moment capacity at the concrete floor slab. Determine if the wall is capable of withstanding the wind pressure. Since the allowable flexural compressive stress is greater than the allowable flexural tensile stress, only the flexural tensile stress needs to be checked. Reference the Overview Section for allowable flexural tensile stress, actual thickness, dry density, and allowable shear stress.

Wall thickness (b) = 8 in nominal (actual = 7.874 in)

Wall height (h) = 10' - 0", including bond beam height of 8 in

Allowable flexural tensile stress increased for wind (F_1) = 24 psi (1.333) = 32 psi

The maximum bending moment at the base of the wall is considered to be:

$$M_{\text{base}} = \frac{(1/2 \times 32 \text{ psi})}{12 \text{ in/ft}} \times \frac{12 \text{ in/ft} (7.874 \text{ in})^2}{6} = 165.3 \text{ ft lbs}$$

Determine the height at which the maximum bending moment occurs:

$$x = \frac{(10 \text{ ft})}{2} + \frac{(165.3 \text{ ft lbs})}{(33 \text{ psf}) (1 \text{ ft}) (10 \text{ ft})} = 5.50 \text{ ft}$$

The maximum bending moment at height x is:

$$M_{\text{max}} = \frac{33 \text{ psf} (1 \text{ ft}) (10 \text{ ft})^2}{8} - \frac{165.3 \text{ ft lbs}}{2} + \frac{(165.3 \text{ ft lb})^2}{2 (33 \text{ psf}) (1 \text{ ft}) (10 \text{ ft})^2} = 334.0 \text{ ft lbs}$$

Bond beam dead load = 30 plf (see Bond Beams, later in this subsection)

Wall dead load above height x (excluding bond beam course)

$$D = \frac{(10.0 \text{ ft} - 0.667 \text{ ft} - 5.50 \text{ ft}) (7.874 \text{ in}) (31 \text{ pcf})}{12 \text{ in/ft}} = 78.0 \text{ plf}$$

Total wall dead load at height x = 30 plf + 78.0 plf = 108 plf

Actual axial compressive stress at height x, $f_a = \frac{108 \text{ lbs/ft}}{7.874 \text{ in} (12 \text{ in/ft})} = 1.15 \text{ psi}$ excluding superimposed axial load

Total allowable flexural tensile capacity = 32 psi + 1.15 psi = 33.15 psi

Actual flexural tensile stress at height x, $f_t = \frac{334.0 \text{ ft lbs} (12 \text{ in/ft})}{12 \text{ in} (7.874 \text{ in})^2} = 32.3 \text{ psi} < 33.15 \text{ psi}$ **OK**

Actual shear at the base of the wall = $\frac{33 \text{ psf} (1 \text{ ft}) (10 \text{ ft})}{2} + \frac{165.3 \text{ ft lbs}}{10 \text{ ft}} = 181.5 \text{ lbs}$

Actual shear stress, $f_v = \frac{181.5 \text{ lbs}}{12 \text{ in} (7.874 \text{ in})} = 1.9 \text{ psi}$

Allowable shear stress for wind load combination, $F_v = 15 \text{ psi} (1.333) = 20 \text{ psi} > 1.9 \text{ psi}$ **OK**

Using the chart, go up from the 10' wall height to the curve for the 8" thick wall and then across to the left axis where the maximum design velocity pressure value of 33 psf is read.

Note: The chart is based upon a dry density of 25 pcf and may be conservatively used for all Strength Classes. If a more exact value is desired, it may be calculated as shown above using the appropriate dry density value.

**Wind Load vs. Wall Height
(All Strength Classes)**

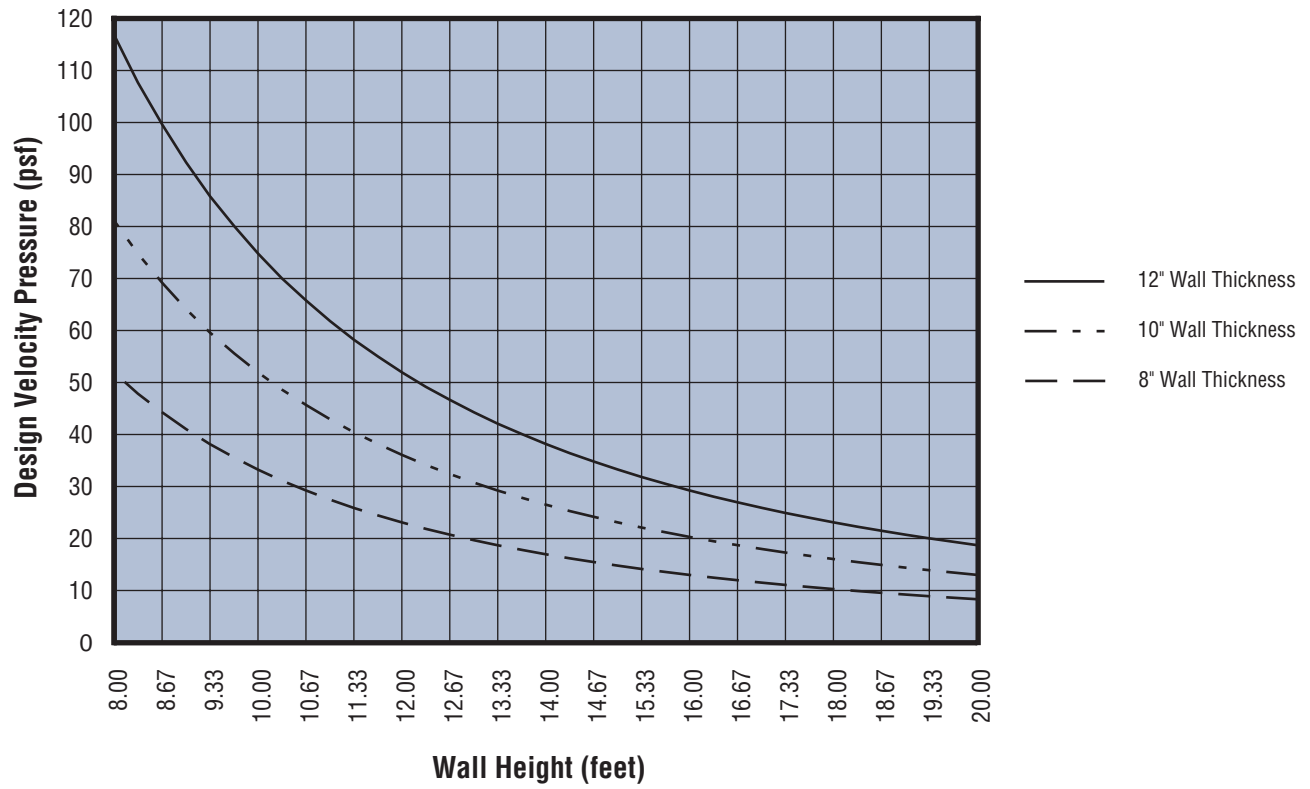

Bond Beams Utilizing AERCON U-Block

Bond beams can be constructed using AERCON U-block to create a continuously reinforced structural element. Two continuous #5 reinforcing bars are held securely in place within the concrete “core” within the U-block, one above the

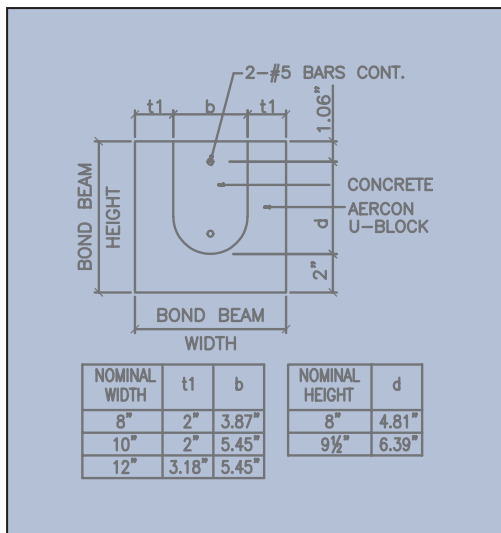

other, accurately positioning the reinforcing bars for resistance to uplift loads.

w_{up} = net uplift at the top of the bond beam, plf

w_{bb} = self-weight of the bond beam, plf

A_s = area of tension rebar, in²

j, k = design factor

n = modular ratio

f'_c = compressive strength of concrete, psi

F_s = allowable tensile stress in rebar, psi

$R = 0.85$, dead load reduction factor

Formulas:

Design assumptions: (1) the bond beam capacity is based upon the size and strength of the concrete “core” within the U-block; (2) the bond beam is a multi-span, continuous beam; (3) the capacity is based upon the cracked concrete “core” using Working Stress Design principles.

The bond beam is checked for shear capacity and moment capacity (reinforcing in tension and concrete in compression). The allowable deflection is $L/600$.

For wind uplift loads, all allowable stresses are increased by one-third.

Moment of Inertia of cracked section ($I_{cracked}$):

$$I_{cracked} = \frac{b(kd)^3}{3} + (nA_s)(d-kd)^2$$

Allowable Shear (V_c):

$$V_c = 1.1(f'_c)^{1/2} bd \text{ (1.333)}$$

Tie-down spacing, shear controlling (s_v):

$$s_v = 2V_c / [w_{up} - w_{bb}(R)]$$

considering a reduction factor for bond beam self-weight.

Maximum nominal reinforcement moment capacity (M_{rebar}):

$$M_{rebar} = A_s F_s jd \text{ (1.333)}$$

Maximum nominal concrete moment capacity (M_{conc}):

$$M_{conc} = (1/2)(0.45)f'_c j k b d^2 \text{ (1.333)}$$

Use the lesser value of M_{rebar} or

M_{conc} for M_{nom} .

Tie-down spacing, moment controlling (s_m):

$$s_m = \{M_{nom}(12) / [w_{up} - w_{bb}(R)]\}^{1/2}$$

Allowable deflection ($\delta = L/600$):

Tie-down spacing, deflection controlling (s_δ):

$$s_\delta = \left[\frac{384 E_c I_{cracked}}{600 [w_{up} - w_{bb}(R)]} \right]^{1/3}$$

Bond Beam Weights:

8" High U-Block

Bond Beam Weights*	
Bond Beam Width (inches)	Bond Beam Weight (plf)
8	30
10	39
12	43

9 1/2" High U-Block

Bond Beam Weights*	
Bond Beam Width (inches)	Bond Beam Weight (plf)
8	38
10	49
12	54

*based on concrete unit weight = 145 pcf

EXAMPLE:

Determine the maximum tie-down spacing for a nominal 8" by 8" AERCON bond beam with a net uplift of 320 plf on the bond beam. Consider $f'_c = 3000$ psi for the concrete fill, with (2) #5 Grade 40 reinforcing bars as shown in the Bond Beam sketch.

An 8" wide bond beam has a self-weight of 30 plf. Determine values for the concrete core.

$$b = 7.874 \text{ in actual width} - 2 \text{ in} - 2 \text{ in} = 3.874 \text{ in} \quad d = 7.874 \text{ in} - 3/4 \text{ in clr} - 1/2 \times 5/8 \text{ in} - 2 \text{ in} = 4.812 \text{ in}$$

$$\rho = \frac{A_s}{bd} = \frac{0.31 \text{ in}^2}{3.874 \text{ in} (4.812 \text{ in})} = 0.016629$$

$$n = \frac{E_s}{E_c} = \frac{29,000,000 \text{ psi}}{57,000 (3,000 \text{ psi})^{1/2}} = 9.29$$

$$\rho n = (0.016629) 9.29 = 0.1545$$

$$k = (2 \rho n + (\rho n)^2)^{1/2} - \rho n = (2 (0.1545) + (0.1545)^2)^{1/2} - 0.1545 = 0.4224$$

$$j = 1 - \frac{k}{3} = 1 - \frac{0.4224}{3} = 0.8592$$

$$I_{\text{cracked}} = \frac{3.874 \text{ in} (0.4224 (4.812 \text{ in}))^3 + (9.29) (0.31 \text{ in}^2) (4.812 \text{ in} - 0.4224 (4.812 \text{ in}))^2}{3} = 33.09 \text{ in}^4$$

$$\text{Allowable shear } V_c = 1.1 (3,000 \text{ psi})^{1/2} (3.874 \text{ in}) (4.812 \text{ in}) (1.333) = 1,498 \text{ lbs}$$

$$\text{Tie-down spacing, shear controlling} = \frac{2 (1,498 \text{ lbs})}{(320 \text{ plf} - 30 \text{ plf} (0.85))} = 10.2 \text{ ft}$$

$$\text{Moment, reinforcing controlling} = \frac{(0.31 \text{ in}^2) 20,000 \text{ psi} (0.8592) (4.812 \text{ in.}) (1.333)}{12 \text{ in/ft}} = 2,848 \text{ ft lbs}$$

$$\text{Moment, concrete controlling} = \frac{(1/2)(0.45)(3,000 \text{ psi})(0.8592)(0.4224)(3.874 \text{ in})(4.812 \text{ in})^2(1.333)}{12 \text{ in/ft}} = 2,442 \text{ ft lbs}$$

$$\text{Tie-down spacing, moment controlling} = \left[\frac{2,442 \text{ ft lbs} (12 \text{ in/ft})}{320 \text{ plf} - 30 \text{ plf} (0.85)} \right]^{1/2} = 10.0 \text{ ft}$$

$$\text{Tie-down spacing, deflection controlling} = \left[\frac{384 (3,122,000 \text{ psi}) (33.09 \text{ in}^4)}{600 (320 \text{ plf} - 30 \text{ plf} (0.85)) 144 \text{ in}^2/\text{ft}^2} \right]^{1/3} = 11.6 \text{ ft}$$

Maximum spacing, controlled by the moment, is 10.0 ft. From the chart, go up from the 320 plf uplift to the nominal 8" thick bond beam curve and read the maximum spacing of 10.0 ft on the left hand side of the chart.

**AERCON Bond Beam Tie-Down Spacing vs. Net Uplift
(8-inch high U-block)**

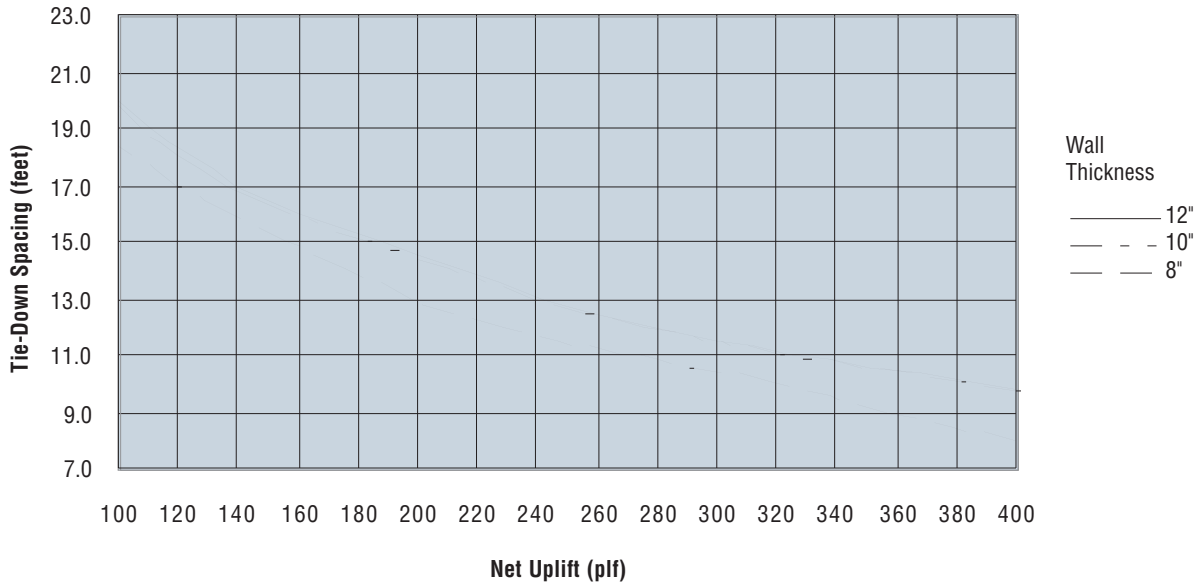

**AERCON Bond Beam Tie-Down Spacing vs. Net Uplift
(9 1/2-inch high U-block)**

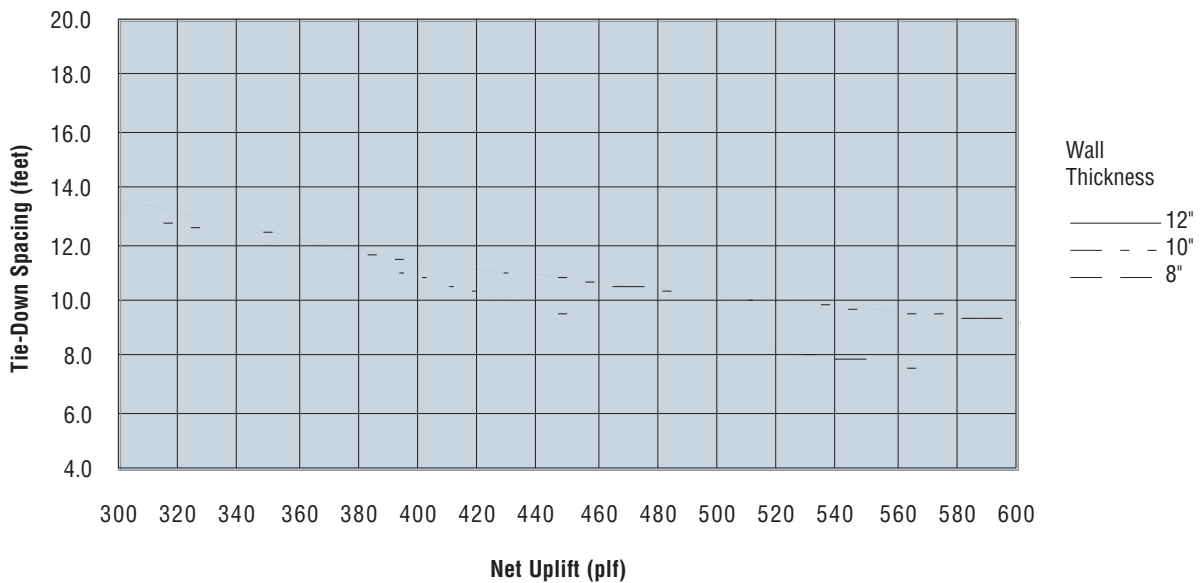

Shear Walls

AERCON shear walls are solid block walls that provide excellent load carrying capacity for diaphragm loads that are transmitted to them from floors or roofs. Shear walls built of solid AERCON block are easy to design and construct. The solid block provides a full bed surface area for AERCON mortar, and therefore, a full block sectional area for shear loads. The tie-down reinforcing, either a threaded rod in a narrow chase, or a threaded rod in ungrouted pre-drilled cores, or standard reinforcing bars grouted solid in pre-drilled cores, provides all of the tensile capacity required.

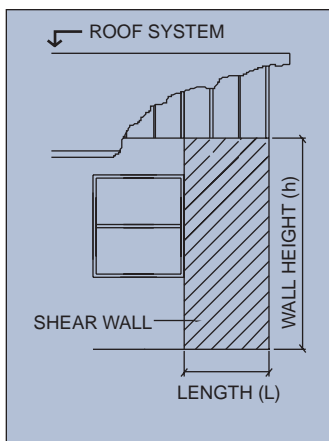

F_b = allowable flexural compressive stress, psi

j, k = design factor

A_s = cross-sectional area of tie-down, in²

F_s = allowable tensile stress in tie-down, psi

F_v = allowable shear stress in AAC, psi

Formulas:

The total lateral force to each shear wall is determined using a typical load apportioning analysis. The net overturning moment is determined and then compared to the resisting moment capacity in compression of the AERCON block and the resisting moment capacity in tension for the tie-down. Finally the shear capacity of the AERCON block is checked.

AERCON compression moment resisting capacity ($M_{r\text{ AAC}}$):

$$M_{r\text{ AAC}} = 1/2 F_b j k b d^2$$

Tensile moment resisting capacity of the tie-down ($M_{r\text{ steel}}$):

$$M_{r\text{ steel}} = A_s F_s j d$$

Shear capacity (V_{AAC}):

$$V_{\text{AAC}} = F_v b d$$

EXAMPLE:

A nominal 8" thick AERCON block wall, Strength Class AC4, eight feet high, must resist an in-plane shear force of 5600 pounds applied at the top of the wall. The overall length of the wall segment is 6'-4" with a single #5, Grade 60 reinforcing bar set back at 4" from each end of the shear wall to resist the net tension that results from the overturning moment. Determine if this shear wall configuration is adequate. Reference the Overview Section for allowable flexural compressive stress, allowable shear stress, modulus of elasticity, nominal dry bulk density and actual thickness for AERCON blocks. Allowable stresses are increased by one-third since the load combination includes lateral load due to wind.

Allowable shear stress in AERCON blocks (F_v) = (15 psi) (1.333) = 20 psi

Allowable flexural compressive stress in AERCON blocks (F_b) = (193 psi) (1.333) = 258 psi

Shear wall height (h) = 8' - 0"

Shear wall length (L) = 6' - 4", less 4" distance from end of wall to tie-down ($d = 6' - 0"$)

Wall thickness (b) = 8 in nominal (actual = 7.874 in) with a nominal dry bulk density γ of 31 pcf

Load at the top of the shear wall (F) = 5,600 lbs

One #5, Grade 60 reinforcing bar at each end of shear wall ($A_s = 0.31 \text{ in}^2$)

$F_s = (24000 \text{ psi}) (1.333) = 32000 \text{ psi}$

$$\rho = \frac{A_s}{b d} = \frac{0.31 \text{ in}^2}{7.874 \text{ in} (6.0 \text{ ft}) 12 \text{ in/ft}} = 0.0005468$$

$$n = \frac{E_s}{E_{AAC}} = \frac{29,000,000 \text{ psi}}{260,000 \text{ psi}} = 111.54 \quad \rho n = 0.06099$$

$$k = \left[2 \rho n + (\rho n)^2 \right]^{1/2} - \rho n = \left[2 (0.06099) + 0.06099^2 \right]^{1/2} - 0.06099 = 0.29355$$

$$j = 1 - \frac{k}{3} = 1 - \frac{0.29355}{3} = 0.90215$$

Check the moment capacity of the wall.

Overturning moment = $F h = 5,600 \text{ lbs} (8.0 \text{ ft}) = 44,800 \text{ ft lbs}$

$$\begin{aligned} \text{Wall dead load moment} &= \frac{h b L^2 \gamma}{2} \\ &= \frac{8.0 \text{ ft} (7.874 \text{ in}) (6.333 \text{ ft})^2 (31 \text{ pcf})}{2 (12 \text{ in/ft})} = 3,263 \text{ ft lbs} \end{aligned}$$

Net overturning moment = $44,800 \text{ ft lbs} - 3,263 \text{ ft lbs} = 41,537 \text{ ft lbs}$

Resisting moments:

$$\begin{aligned} M_{r \text{ AAC}} &= 1/2 F_b j k b d^2 \\ &= 1/2 (258 \text{ psi}) 0.90215 (0.29355) 7.874 \text{ in} (6.0 \text{ ft})^2 (12 \text{ in/ft}) \\ &= 116,206 \text{ ft lbs} > 41,537 \text{ ft lbs} \quad \mathbf{OK}. \text{ Wall is adequate based on flexural compression.} \end{aligned}$$

$$\begin{aligned} M_{r \text{ steel}} &= A_s F_s j d = 0.31 \text{ in}^2 (32,000 \text{ psi}) 0.90215 (6.0 \text{ ft}) = 53,695 \text{ ft lbs} > 41,537 \text{ ft lbs} \quad \mathbf{OK}. \\ &\text{Wall is adequate based on tie-down capacity.} \end{aligned}$$

Check shear capacity of the wall.

$$V_{AAC} = F_v b d$$

$$V_{AAC} = 20 \text{ psi} (7.874 \text{ in}) (6 \text{ ft}) (12 \text{ in/ft}) = 11,339 \text{ lbs} > 5,600 \text{ lbs} \quad \mathbf{OK}. \text{ Wall is adequate based on shear.}$$

AERCON Lintels

AERCON's product line includes two alternatives for load bearing lintels: manufactured reinforced lintels and concrete filled U-block. The minimum bearing length for either style of lintel is 8", across the full thickness of the wall. A longer bearing length is acceptable in order to utilize standard elements to accommodate openings of various widths. To ensure a uniform bearing stress at each end of the lintel, the bearing surface must be true and level. Usually the bottom of the rough opening does not match the block coursing, so an adjustment for the bearing height of the lintel must be incorporated. This is most easily accomplished by cutting pieces of block to the height required to achieve the desired bearing elevation. Adjustment pieces above the lintel may also be required to re-align the block coursing. The minimum height of an adjustment piece is 3".

Manufactured Lintels

AERCON manufactures ready-to-install reinforced lintels in a variety of sizes and lengths. The accompanying table indicates the allowable superimposed loads for these standard pieces. The minimum lintel thickness that attains the tabulated values is 8". For opening widths not specifically listed in

the table, the value for the standard opening width that is larger than the actual width can be conservatively used. An example is included to demonstrate the use of this table. Since the reinforced lintels are uniquely manufactured based on size and load capacity, they cannot be cut, penetrated, or modified without authorization from an AERCON Representative. Each manufactured lintel has a marking indicating the orientation for installation.

Concrete Filled U-Block Lintels

As an alternative, AERCON's U-block can also be used as the "formwork" to create a cast in place concrete lintel. The benefits of using AERCON U-blocks include: the exterior and interior surfaces of the wall are AERCON material, no external formwork is required for the concrete pour, design theory for conventional concrete is utilized to allow evaluation for any opening size, desired elevations can be achieved by cutting the U-block height to adjust for coursing differences, U-blocks can be arranged and poured on site prior to installation in the finished wall if desired. Additionally, U-blocks can be stacked in place to minimize the pouring sequence when the lintel is located near the bond beam course. For this

condition, the upper U-block course must be modified to allow the concrete fill to reach the lower U-block course. For dimensional information for U-blocks, see page VII-30.

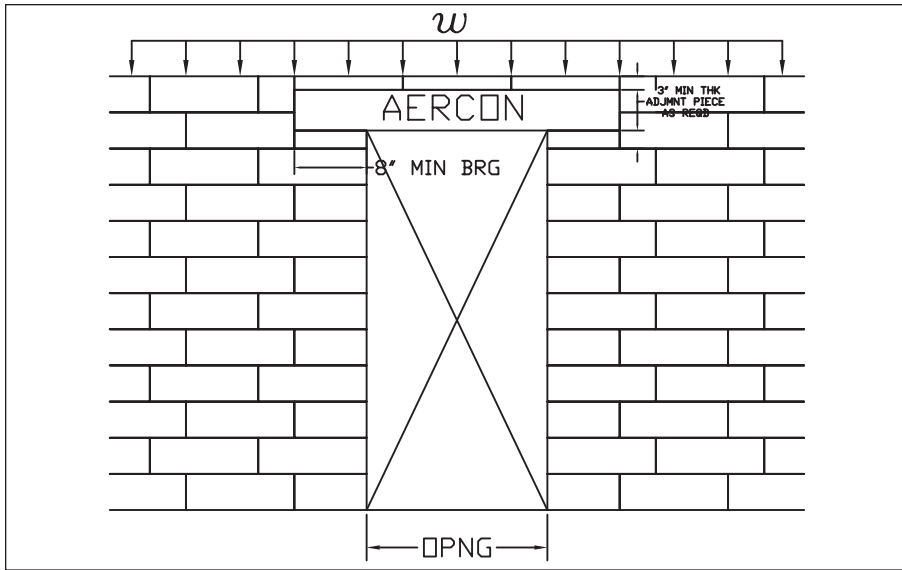

Manufactured Reinforced Lintel

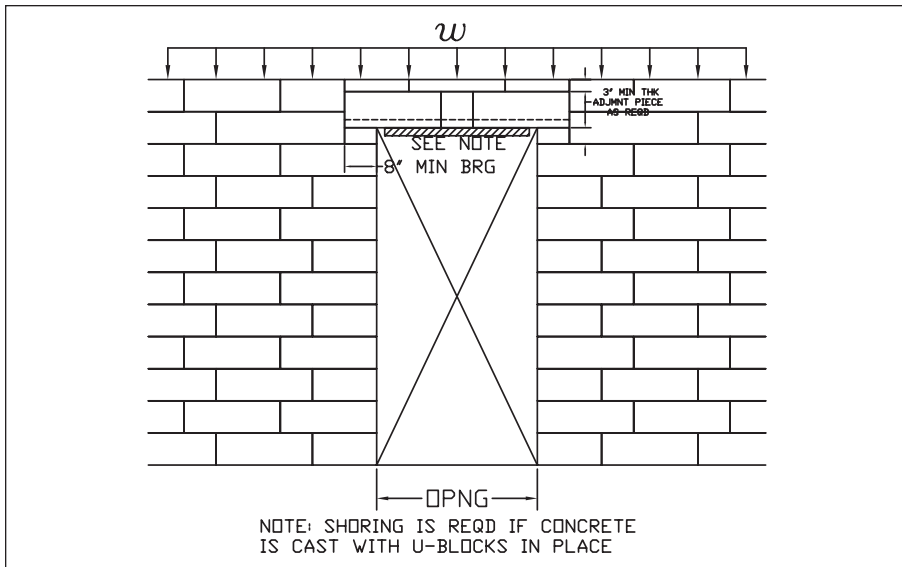

Concrete Filled U-Block Lintel

EXAMPLE:

Select a manufactured lintel to span across an opening that is 4'-6" wide. The wall thickness is 8" and the lintel must support a superimposed load of 600 plf.

Looking in the AERCON Lintel table, use the information for the opening length equal to 4'-8", which is the minimum value greater than the specified width. Select a 12" high lintel which has an allowable superimposed uniform load of 840 plf. An 8" high lintel would not be appropriate since its allowable value of 550 plf is less than the specified load of 600 plf. A 16" or 24" high lintel could be used if the geometry surrounding the opening would benefit from either of those heights.

Specify the chosen lintel as: "AERCON lintel 08x12x072" where 08 is the thickness of 8"; 12 is the height of 12"; and 072 is the standard overall length of 72" (6'-0"). Based on the opening width of 54", the bearing length will be 9" if the lintel is centered above the opening or 8" min at one end and the residual 10" at the other end. As an alternative, determine if a concrete filled U-block lintel is adequate for the specified conditions. Consider $f'_c = 3000$ psi for the concrete fill and a self weight of 30 plf for an 8" high U-block with (2) #5 Grade 60 reinforcing bars. Reference the Bond Beam information for the self-weight and the orientation of the reinforcing bars.

$$\text{For the concrete core: } b = 7.874 \text{ in actual width} - 2 \text{ in} - 2 \text{ in} = 3.874 \text{ in}$$

$$d = 7.874 \text{ in} - 3/4 \text{ in clear} - (1/2) (5/8 \text{ in}) - 2 \text{ in} = 4.812 \text{ in}$$

$$\text{Design shear at the face of the opening} = (600 \text{ superimposed} + 30 \text{ self}) \text{ plf} (4.5 \text{ ft}) / 2 = 1418 \text{ lbs}$$

$$\text{Allowable shear } V_c = 1.1 (3,000 \text{ psi})^{1/2} (3.874 \text{ in}) (4.812 \text{ in}) = 1123 \text{ lbs} < 1418 \text{ lbs NG}$$

Try a 9-1/2 in high U-block.

$$\text{For the concrete core: } b = 7.874 \text{ in actual width} - 2 \text{ in} - 2 \text{ in} = 3.874 \text{ in}$$

$$d = 9.449 \text{ in} - 3/4 \text{ in clr} - (1/2) (5/8 \text{ in}) - 2 \text{ in} = 6.386 \text{ in}$$

$$\text{Design shear at the face of the opening} = (600 \text{ superimposed} + 38 \text{ self}) \text{ plf} (4.5 \text{ ft}) / 2 = 1436 \text{ lbs}$$

$$\text{Allowable shear } V_c = 1.1 (3,000 \text{ psi})^{1/2} (3.874 \text{ in}) (6.386 \text{ in}) = 1,490 \text{ lbs} > 1,436 \text{ lbs OK}$$

$$\rho = \frac{A_s}{b d} = \frac{0.31 \text{ in}^2}{(3.874 \text{ in}) (6.386 \text{ in})} = 0.01253$$

$$n = \frac{E_s}{E_c} = \frac{29,000,000 \text{ psi}}{57,000 (3,000 \text{ psi})^{1/2}} = 9.29$$

$$\rho n = (0.01253) 9.29 = 0.116$$

$$k = (2 \rho n + (\rho n)^2)^{1/2} - \rho n = (2 (0.116) + (0.116)^2)^{1/2} - 0.116 = 0.380$$

$$j = 1 - \frac{k}{3} = 1 - \frac{0.380}{3} = 0.873$$

$$I_{\text{cracked}} = \frac{3.874 \text{ in} (0.380 (6.386 \text{ in}))^3 + (9.29) (0.31 \text{ in}^2) (6.386 \text{ in} - 0.380 (6.386 \text{ in}))^2}{3} = 63.60 \text{ in}^4$$

$$\text{For simple span, } M = (600 \text{ superimposed} + 38 \text{ self}) \text{ plf} (4.5 \text{ ft})^2 / 8 = 1,615 \text{ ft lbs}$$

$$M_{\text{rebar}} = (0.31 \text{ in}^2) (24,000 \text{ psi}) (0.873) (6.386 \text{ in}) (1 \text{ ft}/12 \text{ in}) = 3,456 \text{ ft lbs} > 1,615 \text{ ft lbs OK}$$

$$M_{\text{conc}} = (1/2) (0.45) (3,000 \text{ psi}) (0.873) (0.380) (3.874 \text{ in}) (6.386 \text{ in})^2 (1 \text{ ft}/12 \text{ in})$$

$$M_{\text{conc}} = 2,948 \text{ ft lbs} > 1,615 \text{ ft lbs OK}$$

$$\text{For simple span, deflection} = \frac{5 (600 \text{ superimposed} + 38 \text{ self}) \text{ plf} (4.5 \text{ ft})^4 (12 \text{ in}/\text{ft})^3}{384 (3,122,000 \text{ psi}) (63.60 \text{ in}^4)} = 0.030 \text{ in}$$

$$\text{Considering an allowable deflection} = \text{span} / 600 = (4.5 \text{ ft}) (12 \text{ in}/\text{ft}) / 600 = 0.090 \text{ in} > 0.030 \text{ in OK}$$

Conclusion: A 9-1/2 in high concrete filled U-block is adequate as a lintel based on the criteria and configuration stipulated above.

AERCON Lintels

Allowable Superimposed Uniform Loads (plf)

Thickness = 8 inches

Min Bearing = 8 in at each end

Overall Length		Max. Opening Length	8" high	12" high	16" high	24" high
4 ft 8 in	56 in	3 ft 4 in	840	1355	1965	3835
5 ft 4 in	64 in	4 ft 0 in	675	1060	1550	2605
6 ft 0 in	72 in	4 ft 8 in	550	840	1245	1965
7 ft 4 in	88 in	6 ft 0 in	385	570	955	1165
8 ft 0 in	96 in	6 ft 8 in	335	480	850	935
9 ft 4 in	112 in	8 ft 0 in	255	360	620	1350
11 ft 4 in	136 in	10 ft 0 in	185	245	415	1015
13 ft 4 in	160 in	12 ft 0 in	NR	175	300	805
15 ft 4 in	184 in	14 ft 0 in	NR	135	220	595
17 ft 4 in	208 in	16 ft 0 in	NR	100	165	445
19 ft 4 in	232 in	18 ft 0 in	NR	75	130	340

NOTES:

1. For lengths not listed, use the allowable load for the next longer length listed.
2. Specify lintels as follows: ttxhxdd
 where: tt = thickness in inches (08)
 hh = height in inches (08, 12, 16, or 24)
 ddd = overall length in inches (see table above)
3. NR indicates Not Rated
4. When concentrated loads are to be supported, contact AERCON Technical Services for assistance.
5. Self-weight of lintels can be calculated using 42 pcf.
6. Allowable Superimposed Uniform Loads are provided in pounds per linear foot.

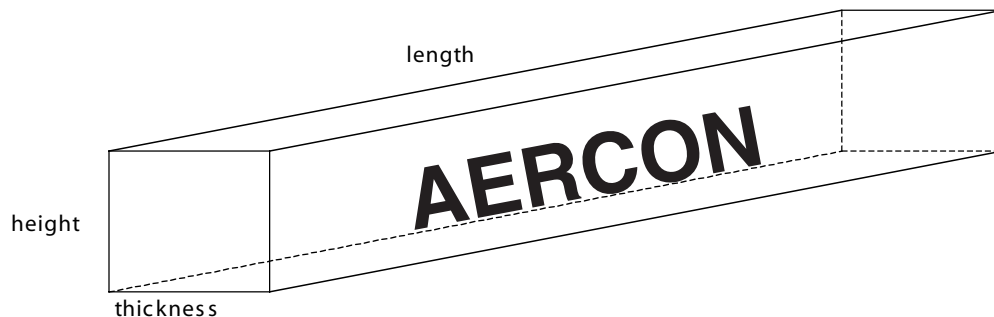

H. Fasteners

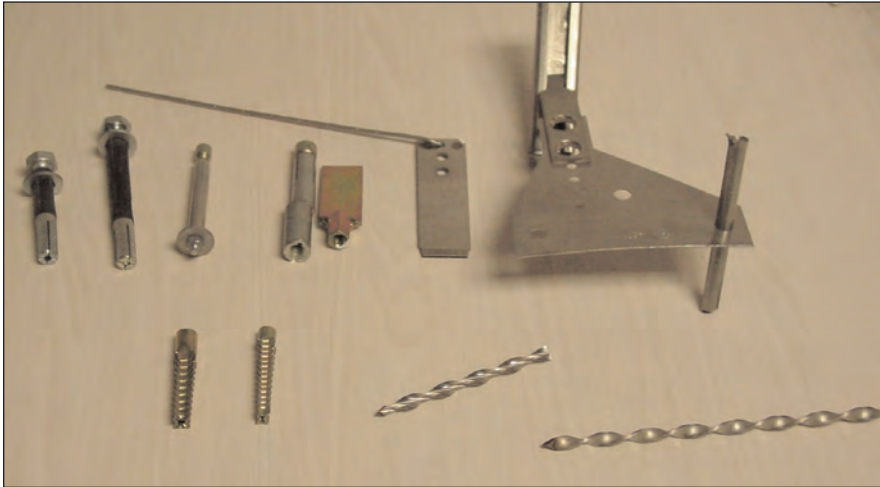

Drop-in anchors, Wakai WPB (internal thread and brick tie), wall plate anchor with anchor rail and tube nail, metal sleeve and spiral-helical anchors.

Square nails, tube nail, HIT nails, deck screws, corrugated nails.



Plastic anchors (integral sleeve, independent sleeve, triangular, spiral) and nylon flare anchors.

Fastener Applications and Suitability

	Square Nail	Tube Nail	Deck Screw	Senco Glue-Tip Nail	Senco Glue-Tip Staple	Hit/Hook Nail	Plastic Sleeve Anchor-Integral Sleeve	Plastic Sleeve Anchor-Independent Sleeve	Plastic Sleeve Anchor-Triangular or Spiral (GB)	Wakai WPB (M8)	Wakai WPB w/Wire	Nylon Flare Anchor	Metal Sleeve	Drop-In Expansion Anchor	Through Bolt	Epoxied Threaded Rod	Spiral - Helical Anchor
Base Boards			X	X	X	X											
Brick Tie			X							X							
Cabinets							X	X	X								
Canopy														X	X	X	
Curtain Tracks			X			X	X	X	X			X					
Door Frame - Metal			X													X	
Door Jamb - Wood			X	X		X											
Fixtures			X			X	X	X	X	X		X	X	X	X	X	X
Foundation Strap		X															
Furring Strips			X			X											X
Gypsum Board	X		X									X					
Handrails							X	X	X					X	X	X	
Pictures	X		X			X						X					
Piping							X	X	X				X	X	X	X	
Shelves							X	X	X	X			X				
Truss Strap		X															
Window Frame			X	X	X												

Fasteners for autoclaved aerated concrete are available in numerous styles from various suppliers. The matrix shown can be used as a guideline to select a particular style depending on the application. Within each style, there may be a variety of sizes and capacities as well. Some fasteners are readily available from domestic suppliers, while certain specialized fasteners are only available from overseas suppliers. Where the latter is true, AERCON intends to maintain an inventory of the most commonly used fasteners and can function as a facilitator for items that it may not have. Determining the type and quantity of fasteners well in advance of when they are required will enable their acquisition to be accomplished most efficiently.

Certain generic fasteners have been tested under contract for AERCON and allowable loads have been included in this manual for those fasteners. For proprietary fasteners, consult the manufacturer's information to determine capacity and appropriate usage. Consult the AERCON web site for the most up-to-date listing of fastener manufacturers.

Manufacturer	Anchor	Description	Diameter (in)	Edge Distance (in)	Anchorage Depth (in)	Allowable loads	
						Shear (lbs) AC4	Tension (lbs) AC4
Senco	Glue-tip nail	8d	-	1	1 3/4	60	-
Senco	Glue-tip staple	2"	-	1	1 1/4	63	-
Generic	Deck Screw	#8 x 3"	-	2 1/2	3	63	86
			-	5	3	65	86
			-	7 1/2	3	66	86
Generic	Tube Nail	100 mm	9 mm	2 1/2	4	143	-
				5	4	271	-
				7 1/2	4	288	-
				2 1/2	3 1/4	-	133
				7 1/2	3 1/4	-	200
Generic	Square Nail	100 mm	4 mm	2 1/2	2 1/2	55	56
				5	2 1/2	65	56
				7 1/2	2 1/2	65	56
Generic	Epoxyed Reinf. Bar ³	#4 & #5	1/2 & 5/8	4	6	-	410
				4	8	-	415
				4	12	-	550
				12	6	445	-
				12	8	525	-
				12	12	685	-

Notes: 1. All test values noted above were performed with Strength Class AC4 material.

2. The allowable shear and tension values are calculated as follows:

$$\text{Allowable Load} = \frac{\text{Ultimate Average Test Value} - (2 \times \text{Standard Deviation})}{3}$$

3. Allowable loads are based on slow-set epoxy.

I. Notation

- A = bed area of the wall based on a solid cross-section, in²
 AAC = autoclaved aerated concrete
 A_s = area of reinforcing steel in a reinforced element or cross-sectional area of a tie-down, in²
 A_{vt} = area of shear reinforcement in a diaphragm bond beam, in²
 b = width or thickness of element considered, in
 d = distance from extreme flexural compressive fiber to the centroid of the reinforcing steel in a reinforced element, in
 D = dead load of AAC wall due to self-weight, lb
 E_c = modulus of elasticity of normal weight concrete, psi
 E_{AAC} = modulus of elasticity of AAC, psi
 E_s = modulus of elasticity of reinforcing steel, psi
 e = eccentricity of a superimposed axial load, in
 F = actual in-plane force at the top of a shear wall, lb
 F_a = allowable axial compressive stress in AAC, psi
 f_a = actual axial compressive stress in AAC, psi
 F_b = allowable flexural compressive stress in AAC, psi
 f_b = actual flexural compressive stress in AAC, psi
 f'_c = minimum specified compressive strength of normal weight concrete, psi
 f'_{AAC} = minimum specified compressive strength of AAC, psi
 F_s = allowable tensile stress in reinforcing steel or tie-down, psi
 f_s = actual tensile stress in reinforcing steel, psi
 F_t = allowable flexural tensile stress in AAC, psi
 f_t = actual flexural tensile stress in AAC, psi
 F_v = allowable shear stress in AAC, psi
 f_v = actual shear stress in AAC across the thickness of the element, psi
 h = effective height of wall, ft
 H = depth of a diaphragm measured in a horizontal direction, ft
 I = moment of inertia of wall based on a solid cross-section, in⁴
 $I_{cracked}$ = cracked moment of inertia for normal weight concrete, in⁴
 j = factor determined based on an elastic analysis of a reinforced concrete section
 k = factor determined based on an elastic analysis of a reinforced concrete section
 L = length of AAC shear wall, ft
 M = actual design moment for analysis, ft k or ft lb
 M_{base} = moment considered at the base of an AAC wall, ft lb

M_{conc} = allowable moment for a reinforced concrete section when the concrete is the controlling element, ft lb
 M_{max} = maximum moment occurring in an AAC wall due to lateral load, ft lb
 M_{nom} = allowable moment for a reinforced normal weight concrete section, ft lb
 M_{OTM} = overturning moment for shear wall design, ft lb
 M_r = resisting moment of shear wall based on dead load, ft lb
 M_{AAC} = allowable moment for an AAC shear wall when flexural compression is the controlling criteria, ft lb
 M_{rebar} = allowable moment for a reinforced concrete section when the reinforcing steel is the controlling element, ft lb
 M_{steel} = allowable moment for an AAC shear wall when tension in the tie-down is the controlling criteria, ft lb
 n = modular ratio of AAC or conventional concrete to reinforcing steel
 P_{ac} = allowable superimposed axial compressive load for AAC when compressive stress is the controlling criteria, lb
 P_{at} = allowable superimposed axial compressive load for AAC when flexural tensile stress is the controlling criteria, lb
 P_v = allowable in-plane force at the top of a shear wall, lb
 R = dead load reduction factor
 r = radius of gyration of wall based on a solid cross-section, in
 S = section modulus of wall or diaphragm based on a solid cross-section, in³
 s_o = spacing of tie-downs resisting uplift when deflection in the bond beam is the controlling criteria, ft
 s_m = spacing of tie-downs resisting uplift when moment in the bond beam is the controlling criteria, ft
 s_v = spacing of tie-downs resisting uplift when shear in the bond beam is the controlling criteria, ft
 T = tension force used to resist overturning of a shear wall, lb
 T_c = tensile chord force in a diaphragm system, lb or kip
 t = thickness of element, in
 V = actual shear force at location of interest for diaphragm analysis, lb
 v = actual shear force per unit length at location of interest for diaphragm analysis, plf
 V_{AAC} = shear strength provided by AAC, lb
 V_c = shear strength provided by normal weight concrete, lb
 V_g = allowable shear force for a grouted joint or bond beam for diaphragm analysis, plf
 V_s = shear strength provided by shear reinforcement in normal weight concrete, lb
 V_u = design shear force, lb
 w = design velocity pressure due to wind, psf; or uniform load for beam analysis, plf; or superimposed dead load, plf
 w_{bb} = self-weight of bond beam, plf
 w_{up} = uplift load resisted by a bond beam, plf
 x = height above floor at which the maximum flexural moment occurs in an AAC wall, ft
 γ = nominal dry bulk density of AAC, pcf
 γ_D = design dead weight of AAC, pcf
 ρ = ratio of reinforcing steel area to concrete area, A_s/bd
 μ = coefficient of friction