

II. Overview



AERCON panels are installed by crane and clamp.

A. AERCON Building Systems

B. AERCON Product Line

C. Installation

D. Properties of AERCON Products

E. Standards and Approvals

F. Ecology

Page II-2

Page II-4

Page II-6

Page II-8

Page II-10

Page II-14

A. AERCON Building Systems

AERCON load bearing and non-load bearing wall, floor and roof systems are combined to form the solid basis for entire single and multi-story buildings as shown.

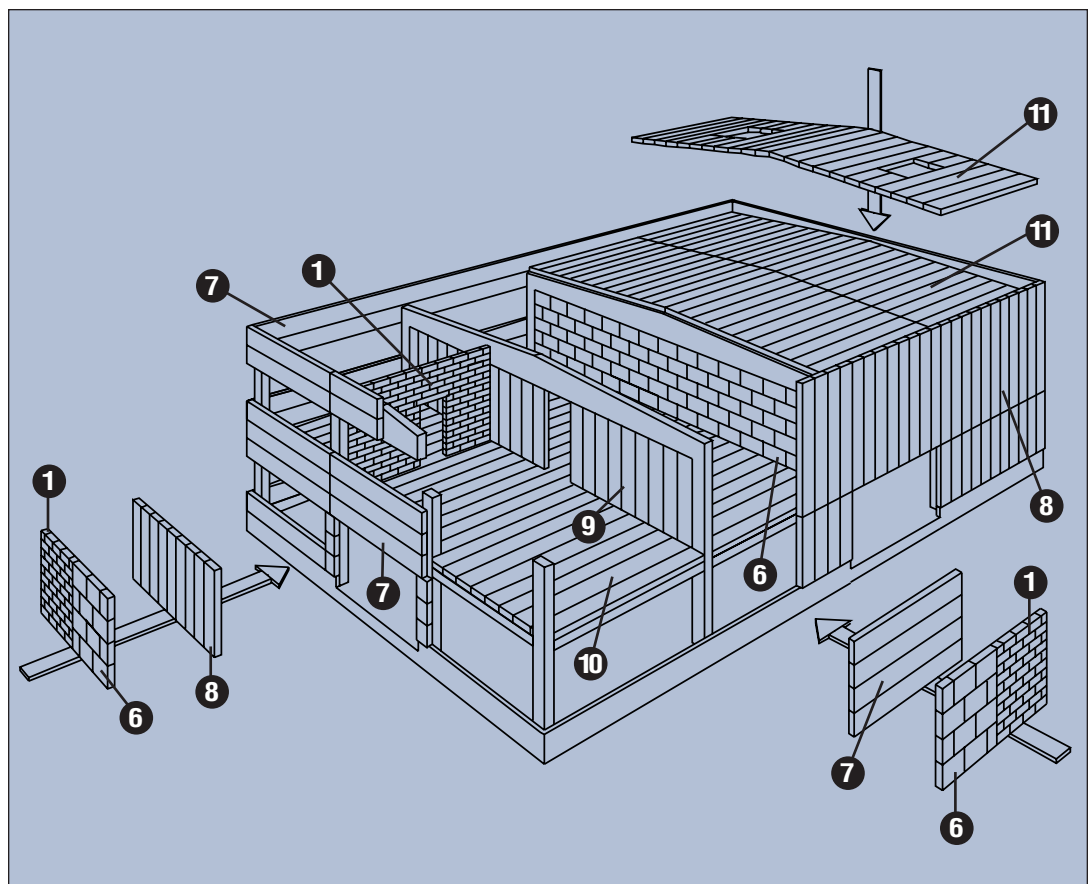

Non-Load Bearing Wall System

(with load bearing concrete or steel structures)

AERCON Roof and Floor Panels

AERCON Curtain Walls or AERCON Infill Block

AERCON Partitions

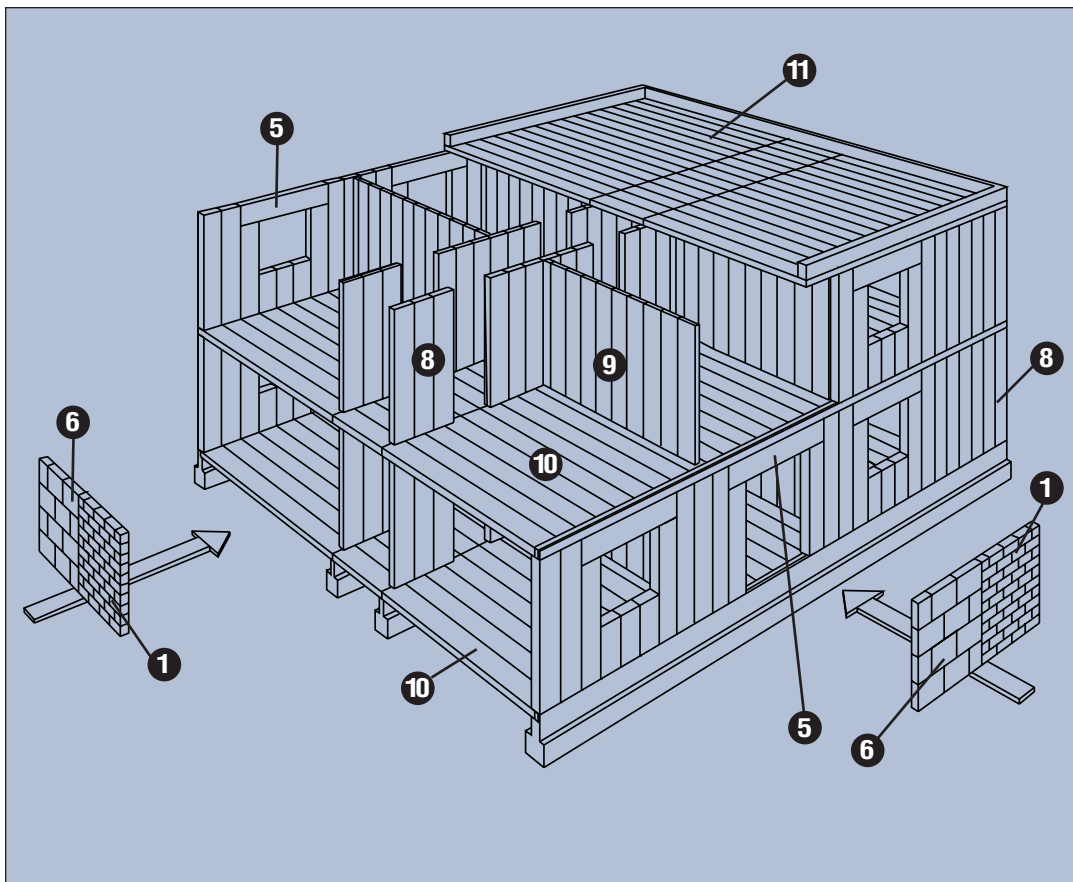

Load Bearing Wall System

Load Bearing AERCON Walls using AERCON Panels or Block

AERCON Roof and Floor Panels

AERCON Partitions

B. AERCON Product Line

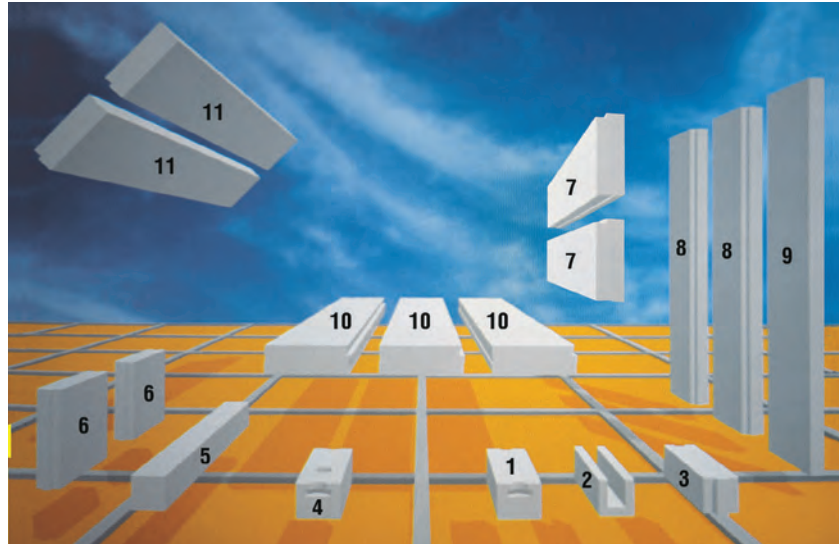

	Product	Available Dimensions (Nominal)	Strength Class
1.	Block Handholds in 8" thick blocks or greater	Length: 24" Height: 8" Thickness: 4", 6", 8", 10", 12"	AC2 AC4 AC6
2.	U-Block	Length: 24" Height: 8", 9 1/2" Thickness: 8", 10", 12"	AC4
3.	Tongue & Groove Block Handholds in 8" thick blocks or greater	Length: 24" Height: 8" Thickness: 4", 6", 8", 10", 12"	AC2 AC4 AC6
4.	Cored Block	Length: 24" Height: 8" Thickness: 8", 10", 12"	AC2 AC4 AC6
5.	Lintel	Length: 8' 0" max. Height: 8" Thickness: 8", 10", 12"	AC4
6.	ValuBlock Flat face or with tongue & groove ends	Length: 24" Height: 24" Thickness: 4", 6", 8", 10", 12"	AC2 AC4 AC6
7.	Horizontal Wall Panel	Length: 20'0" max. Height: 24" max. Thickness: 6", 8", 10", 12"	AC4 AC6
8.	Vertical Wall Panel	Height: 20'0" max. Width: 24" max. Thickness: 6", 8", 10", 12"	AC4 AC6
9.	Interior Wall Partition	Height: 9'8" Width: 24" Thickness: 4"	AC4
10.	Floor Panel	Length: 20'0" max. Width: 24" max. Thickness: 8", 10", 12"	AC4 AC6
11.	Roof Panel	Length: 20'0" max. Width: 24" max. Thickness: 8", 10", 12"	AC4 AC6

Standard Joint Profiles

- Sure Interlocking Joints
- Easy Joint Alignment
- Solid Structural Integrity

Wall Panels with Tongue and Groove or Plain Joints.

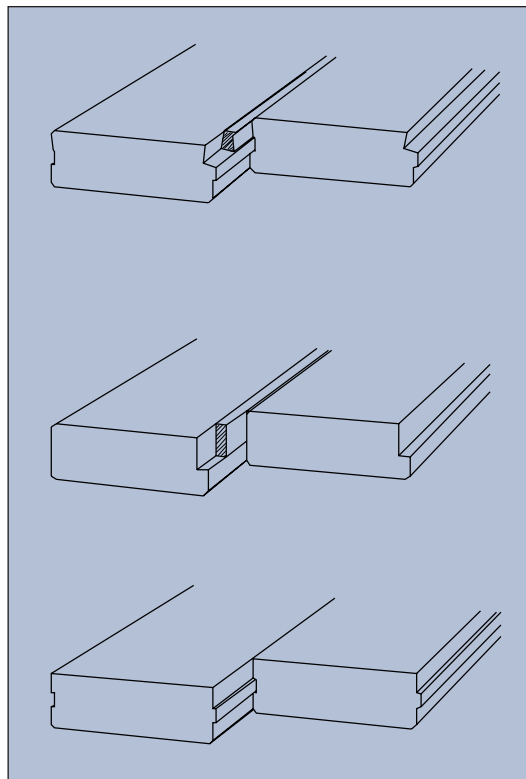
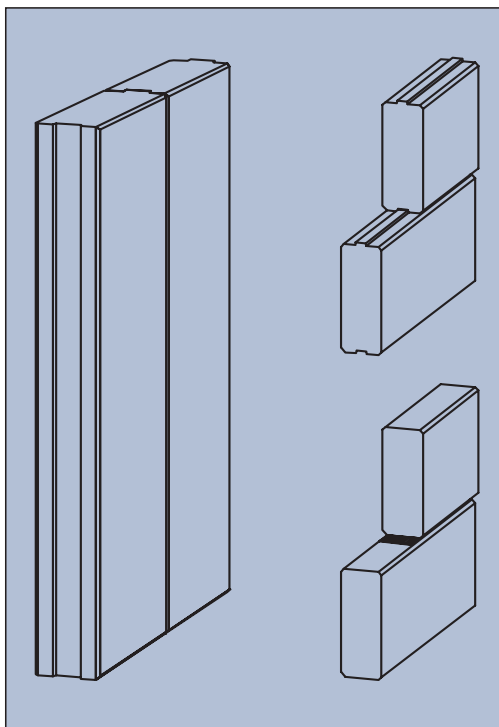

Floor and Roof Panels with and without Key Joint Grouting.

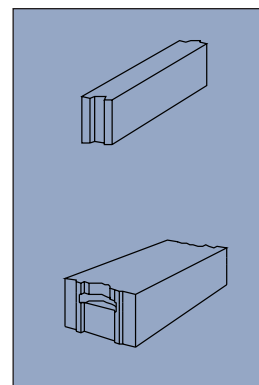

Blocks with Tongue and Groove.

C. Installation

AERCON Lintel and Load Bearing Wall Panel Installation



AERCON Non-load Bearing Vertical Wall Panel Installation



AERCON Floor/Roof Panel Installation





AERCON Interior Wall Partition
Installation



AERCON ValuBlock
Installation



AERCON Block
Installation

D. Properties of AERCON Products

Energy Efficiency

An 8-inch AERCON wall outperforms conventional wood frame and concrete masonry construction for energy efficiency (equivalent R-value). This exceptional energy efficiency is achieved by a very low thermal conductivity (U-value) along with the thermal mass effect. This is a distinct benefit of the AERCON aerated concrete construction over other conventional building systems such as wood frame and concrete masonry construction.

In order to compare an AERCON exterior wall with conventional wall construction methods - wood stud frame and concrete masonry - the Florida Solar Energy Center determined equivalent R-values for an 8-inch AERCON wall. Weather data for Orlando, Florida as developed in the Typical Meteorological Year (TMY 1981) database served as the basis for the outside conditions. For example, during an average summer day, the 8-inch AERCON wall performs like either a wood stud frame wall insulated with R-20.4 fiberglass batt insulation or an 8-inch CMU block wall insulated with R-8.6 rigid insulation.

Fire Resistance

AERCON is non-combustible. So in the case of fire, no toxic gases or vapors are emitted.

Solid AERCON construction, without any additional finishing materials, provides a fire rating of 4 hours for a 4-inch thick block wall or 6-inch thick panel wall, based on UL tests. This exceptional rating meets even the most stringent requirements of typical building codes. Additional fire-rated block, panel, penetration, and joint systems are described in the Fire Resistance Section.

Sound Insulation

AERCON, a porous concrete material, provides a sound insulation value of 7dB greater than other building materials of the same weight per surface area. AERCON's high surface mass coupled with the mechanical vibration energy damping within its porous structure produces a construction material with exceptional sound insulation properties.

The following examples show the STC⁽¹⁾ rating for typical AERCON wall construction:

- Solid AERCON walls, including finish plaster on both sides:

<u>Wall Thickness</u>	<u>STC</u>
4 inches	36
8 inches	44

(1) STC = Sound Transmission Class

Additional examples and information can be found in the Acoustic Performance information in the Architectural Design Section.

Block Products

	Strength Class			Units
	AC2	AC4	AC6	
Minimum Compressive Strength of AAC, f_{AAC}	348 (2.4)	580 (4.0)	870 (6.0)	psi (MPa)
Allowable Flexural Compressive Stress in AAC, F_b	116 (0.8)	193 (1.3)	290 (2.0)	psi (MPa)
Allowable Axial Compressive Stress in AAC, F_a	87 (0.6)	145 (1.0)	217 (1.5)	psi (MPa)
Allowable Flexural Tensile Stress in AAC, F_t	24 (0.16)	24 (0.16)	24 (0.16)	psi (MPa)
Allowable Shear Stress in AAC, F_v	9 (0.06)	15 (0.10)	22 (0.15)	psi (MPa)
Modulus of Elasticity of AAC, E_{AAC}	190×10^3 (1300.)	260×10^3 (1800.)	360×10^3 (2500.)	psi (MPa)
Coefficient of Thermal Expansion of AAC	4.4×10^{-6} (8×10^{-6})	4.4×10^{-6} (8×10^{-6})	4.4×10^{-6} (8×10^{-6})	1/°F (1/K)
Thermal Conductivity of AAC	0.80 (0.11)	0.97 (0.14)	1.25 (0.18)	BTU in / ft ² h °F (W/m K)
Design Dead Weight of AAC, γ_b	31 (5.0)	37 (6.0)	47 (7.5)	pcf (kN/m ³)
Nominal Dry Bulk Density of AAC, γ	25 ± 1.6 (400 ± 25)	31 ± 1.6 (500 ± 25)	40 ± 1.6 (650 ± 25)	pcf (kg/m ³)

Strength Class

There are 3 Strength Classes defined for AAC block products in ASTM C 1386 and 3 Strength Classes defined for reinforced AAC elements in ASTM C 1452. Since the AAC physical requirements identified in each specification are the same, AERCON uses abbreviated identifications for the ASTM designations as shown in the table below. The same AERCON designation is used for block products and for reinforced elements.

AERCON Designation	ASTM C 1386 Designation	ASTM C 1452 Designation
AC2	PAAC-2	AAC-2
AC4	PAAC-4	AAC-4
AC6	PAAC-6	AAC-6

The Product Line table on Page II-4 of this section identifies the Strength Classes available for each AERCON product. When wall plate anchors are used to connect cladding panels to a superstructure, the Strength Class for those panels may be identified as AC3.3 or AC4.4 based on the connection capacity required. Wall plate anchors as shown in the Construction Details Section have published capacities based on these two Strength Classes.

Dimensions

Nominal dimensions for thickness of products are referred to in various sections of this manual. The table below shows the manufactured dimensions associated with the nominal dimensions.

Nominal Thickness	Actual Thickness	
	inches	mm
4	3.94	100
6	5.91	150
8	7.87	200
10	9.45	240
12	11.81	300

E. Standards and Approvals

The quality of AERCON products is unsurpassed in the autoclaved aerated concrete industry and our ongoing commitment to product testing confirms our total commitment to quality. AERCON products have been tested in accordance with or conform to the standards listed in the table. The following sections provide a general description of each standard. AERCON is always striving to have complete technical information to support the design professionals!

ASTM C 426

“Standard Test Method for Drying Shrinkage of Concrete Masonry Units”

When designing and constructing a building, an allowance must be made for the normal drying shrinkage of the construction as the materials stabilize to their final environmental conditions. If this typical drying shrinkage is not properly compensated for, cracking may result at restrained locations around the building envelope.

This test method provides a standardized procedure for determining the drying shrinkage of masonry units when dried according to certain accelerated conditions. The test specimens are first submerged in water, then air-dried, and then oven-dried. At each stage, the length is measured. Formulas are given for calculating the drying shrinkage.

Standards and Approvals

Standard	Description
ASTM C 426 Drying Shrinkage of Concrete Masonry Units	Determine Material Shrinkage Characteristics
ASTM C 1386 Precast Autoclaved Aerated Concrete Wall Construction Units	Specification for Physical Requirements for AAC Block Products
ASTM C 1452 Reinforced Autoclaved Aerated Concrete Elements	Specification for Physical Requirements for Reinforced AAC Elements
ASTM E 72 Strength Tests of Panels for Building Construction	Determine Wall Flexural Strength
ASTM E 90 Laboratory Measurement of Airborne Sound Transmission Loss of Building Partitions	Determine Sound Transmission Class
ASTM E 447 Compressive Strength of Masonry Prisms	Determine Compressive Strength
ASTM E 514 Water Penetration and Leakage Through Masonry	Determine Ability of a Wall System to Prevent a Driving Rain from Penetrating the Building Envelope
ASTM E 518 Flexural Bond Strength of Masonry	Determine Flexural Bond Strength
ASTM E 519 Diagonal Tension (Shear) in Masonry Assemblages	Determine Wall Shear Strength
ANSI/UL 263 / ASTM E 119 Fire Tests of Building Construction and Materials	Determine Fire Rating
ANSI/UL 2079 Fire Resistance of Building Joint Systems	Determine Fire Rating for Joint Systems

ASTM - American Society for Testing and Materials
UL - Underwriters Laboratories, Inc.

ASTM C 1386

“Standard Specification for Precast Autoclaved Aerated Concrete (PAAC) Wall Construction Units”

This specification addresses various aspects of autoclaved aerated concrete units, including physical characteristics such as compressive strength, dimensional tolerance, drying shrinkage and bulk density, as well as the quality of the raw materials used for production. In addition, this specification identifies Strength Classes with their associated numeric values for compressive strength and density. Detailed test procedures for determining compressive strength, dry bulk density, moisture content, and drying shrinkage are also described.

ASTM C 1452

“Standard Specification for Reinforced Autoclaved Aerated Concrete Elements”

Reinforced elements consist of steel reinforcing bars welded into mats and encapsulated by autoclaved aerated concrete. The design of these elements for the anticipated loading conditions requires assurance of the physical properties of each component that make up a reinforced element. The performance of a reinforced element is dependent on the strength of the AAC, the strength of the reinforcing bars, and the strength of the welds that secure the bars together. Protection against degradation of the reinforcing bars is a critical feature that assures long-term structural integrity.

This standard references pertinent sections of ASTM C 1386 and also contains additional requirements for the reinforcement. The physical attributes of AAC compressive strength, bulk density, and drying shrinkage are determined based on the test procedures described in ASTM C 1386. Requirements for raw materials, steel strength, weld strength, and corrosion protection are identified in this standard. Test procedures for determining these characteristics, as well as performance when subjected to flexural loading, are also included.

ASTM E 72

“Standard Test Methods of Conducting Strength Tests of Panels for Building Construction”

In order to achieve the proper structural design of a building to resist lateral wind loads, the flexural bending strength of the basic structural elements used in the construction must be known.

This test method provides a standardized procedure for obtaining the flexural bending strength by means of the application of a uniform pressure to the entire test wall surface, simulating wind pressure on the actual construction. To determine the flexural tensile strength perpendicular to the wall bed joints, a large air bag is placed between the test specimen and a reaction frame. The air pressure within the bag is increased until failure of the specimen occurs. The failure pattern of each spec-

imen is noted and the ultimate flexural tensile strength, standard deviation and coefficient of variation are calculated.

ASTM E 90

“Laboratory Measurement of Airborne Sound Transmission Loss of Building Partitions”

For walls, floors and other building assemblages, the ability to reduce the sound from one side of the assemblage to the other is important in terms of the comfort of the occupants of any building, whether it is a single family residence or a multi-story office structure.

This test method provides a standardized procedure for measuring the sound transmission loss in decibels (dB) in the frequency range of 125 to 4000 hertz. In order to determine its acoustic effectiveness, a building assemblage is constructed between a sound source room and a receiving room. A sound field is produced and measured in the source room and the sound field in the receiving room is also measured. The sound pressure levels in the two rooms, the sound absorption in the receiving room and the area of the specimen are used to calculate transmission loss at a series of frequency bands. From this information, a Sound Transmission Class value can be calculated.

ASTM E 447

“Compressive Strength of Masonry Prisms”

In order to achieve the proper structural design of a building to resist gravity loads, the compressive strength of the basic structural elements used in its construction must be accurately known.

This test method provides a standardized procedure for obtaining the compressive strength of masonry by the application of a compressive load to a prism constructed of masonry units. The compressive load is applied to the prism using a spherically seated, hardened metal bearing block above the specimen and a hardened metal bearing block below the specimen. This ensures that a concentric load is applied uniformly over the entire area of the prism. The results of the test provide the engineering design property known as the minimum compressive strength of masonry, which for AERCON products is f'_{AAC} . The minimum compressive strength of masonry is then used in the determination of the allowable axial stress, the allowable compressive bending stress and the moment resisting capacity as limited by compression in AERCON assemblies.

ASTM E 514

“Standard Test Method for Water Penetration and Leakage Through Masonry”

Buildings must perform well under severe weather conditions

including frequent, intense thunderstorms accompanied by high winds. The wall systems used in typical building construction must be able to prevent the rain from getting into the interior of the building envelope.

This test method provides a standardized procedure for determining the amount of water that completely penetrates a wall assemblage. The amount of pass-through water is obtained by subjecting an entire wall assembly to an application of water at a rate of 3.4 gal/ft² per hour with an air pressure of 10 lb/ft² for not less than 4 hours. This is equivalent to a 62 mph wind speed and 5½ inches of rain per hour. Any water that penetrates the assemblage is collected, measured and reported.

ASTM E 518

“Standard Test Methods for Flexural Bond Strength of Masonry”

In order to achieve the proper structural design of imposed loads, the flexural bond strength between the basic structural elements used in the construction must be known.

There are two test methods delineated in this standard that provide standardized procedures for determining the flexural bond strength of unreinforced masonry assemblages. Both test methods utilize a prism constructed of multiple masonry units. The prism is tested as a simply supported beam, uniformly loaded by means of an

air bag in one method and third-point loaded in the other. The load is increased until failure of the specimen occurs. The failure load is then used to calculate the gross area modulus of rupture.

ASTM E 519

“Standard Test Methods for Diagonal Tension (Shear) in Masonry Assemblages”

In order to achieve the proper structural design of a building to resist lateral loads utilizing shear walls, the strength and rigidity of the basic structural elements used in the shear wall construction must be accurately known.

This test method provides a standardized procedure for determining the diagonal tensile (shear) strength of masonry assemblages. The specimen size permits a reasonable evaluation of the shear strength that would be representative of a full-size masonry wall used in actual construction. Each specimen is constructed of blocks in a running bond pattern. The rectangular specimen is rotated 45 degrees when it is placed into the testing machine, so that its diagonal axis is oriented vertically. The specimen is then loaded in compression along that vertical diagonal axis. This results in a diagonal tension failure, with the specimen splitting apart in a direction parallel to the load application. The failure pattern of each specimen is noted and average shear strength, standard deviation and coefficient of variation are calculated.

ANSI / UL 263 (ASTM E 119 similar)

“Standard Test Methods for Fire Tests of Building Construction and Materials”

The performance of roofs, floors and walls when exposed to fire is important for the safety and security of the occupants of a building, their belongings and the building contents.

This test method provides a standardized procedure for determining the fire rating for restrained roofs and floors; the fire rating for unrestrained roofs and floors; the fire rating for load bearing walls; and the fire rating for non-load bearing walls when subjected to a standard fire exposure. Where applicable, a superimposed load is used to simulate the maximum design load for the assemblage. This test method provides a relative measure of the ability of an assemblage to prevent the spread of a fire while maintaining its structural integrity.

To determine its fire rating, an assemblage is constructed and exposed to a standard fire for a predetermined amount of time. After the assemblage is subjected to the standard fire exposure, it is subjected to a standard fire hose stream of water, intended to simulate the effects of fire fighting efforts. An assemblage is considered to have passed the fire exposure portion of the test if the temperature on the unexposed face remains below a cer-

tain value, thus measuring its heat transmission. An assemblage is considered to have passed the hose stream portion of the test if it does not allow any water to seep through to the unexposed face. The assemblage must successfully pass both portions of the test in order to achieve its fire rating. The fire rating is assigned based on the amount of time that the assemblage was exposed to the standard fire, normally specified as a 1, 2, 3 or 4 hour rating.

ANSI / UL 2079

“Tests for Fire Resistance of Building Joint Systems”

There are conditions in building design where a physical separation between adjacent fire rated elements is either desirable or required, such as an interior wall abutting perpendicular to an exterior wall. A gap between these walls provides for independent movement and construction tolerance. If these are fire rated walls, any gap or joint that exists between these elements must also be fire rated.

This test method provides a standardized procedure for determining the fire rating of joint systems used for sealing any continuous aperture between fire rated elements. To determine its fire rating, an assemblage is constructed which contains the joint system. After the assemblage is constructed, it is cycled to simulate movement that may occur in a

completed installation. It is then exposed to a standard fire for a predetermined amount of time. After the assemblage is subjected to the standard fire exposure, it is subjected to a standard fire hose stream of water, intended to simulate the effects of fire fighting efforts. An assemblage is considered to have passed the fire exposure portion of the test if the temperature on the unexposed face remains below a certain value, thus measuring its heat transmission. An assemblage is considered to have passed the hose stream portion of the test if it does not allow any water to seep through to the unexposed face. The assemblage must successfully pass both portions of the test in order to achieve its fire rating. The fire rating is assigned based on the amount of time that the assemblage was exposed to the standard fire, normally specified as a 1, 2, 3 or 4 hour rating.

F. Ecology

The Ingredients - Use of Natural Resources

AERCON is a purely mineral-based building material, made from sand, water and limestone. These natural materials are major components of the earth's crust and can be found in almost unlimited quantities throughout the world. Since the sources of the raw materials are practically inexhaustible, the environment

is not being robbed of irreplaceable resources. These raw materials are processed to provide a building material with a large number of air pores - aerated concrete. Due to our unique hydration process, the batched mixture

of raw materials "rises". Thus, one unit of volume of raw materials will yield five units of volume of AERCON.

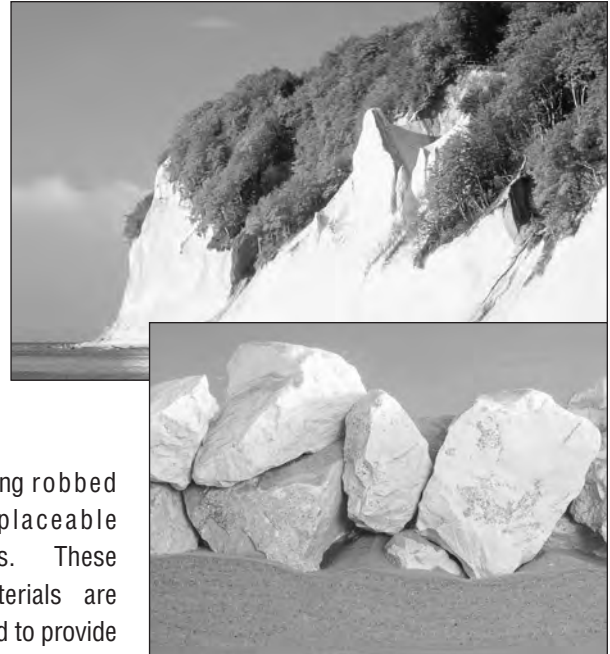

Environmentally-Protective Production Process

Chemically, AERCON is a calcium silicate hydrate that is created during the hardening of the raw material mixture. This is the equivalent of the mineral, "Tobermorite", that occurs in nature. A rising agent acts as a pore generating agent. After stiffening, the risen mass is cut into the desired dimensions and then steam-cured under pressure in an autoclave. During the production process, there is no emission of toxic or environmentally hazardous by-products.

During the trimming process, the trimmings are returned to the initial mixture, eliminating

the loss of raw materials.

Energy is saved in the curing process where the hot steam used in the autoclaves is

reclaimed for reuse. This technically advanced process conserves precious energy resources.



The steam curing production method helps conserve energy since steam curing is carried out at relatively low temperatures and thermal energy is recovered for maximum efficiency.

An Energy-Conserving Way to Build

The lightweight properties of AERCON autoclaved aerated concrete products are also very favorable characteristics for the environment.

Energy consumption and costs for delivering AERCON products to the project site are reduced due to AERCON's light weight.

The manpower and equipment required to install AERCON

building systems can be efficiently utilized in all phases of construction. The ease in which the material is cut, shaped and placed allows for easy fit-up with less physical energy consumed and fewer fuel-driven machines being required.

AERCON's high insulating properties, which surpass most other building products, also

provide on-going energy savings for the building owner by increasing the building's thermal efficiency. Since the use of this material can also allow the owner to take advantage of "off peak" energy use, additional savings can be seen by the owner and reduced demand of "on peak" energy can be achieved for the power company.

AERCON wall panels were chosen to build several Communication Equipment Buildings in order to lower their operating costs with savings from energy efficiency.



AERCON's Uses - Safe and Healthy for the Environment

The exceptionally good thermal insulation property of AERCON sets the standard for energy conservation, which reduces the generation and emission of CO₂.

Due to its purely mineral composition, AERCON is non-combustible and no toxic fumes are generated.

AERCON also provides a comfortable environment due to its good sound insulation in buildings.

