

Nothing Outperforms AERCON!

Fast-Track Building Solutions



AERCON's 100,000 sq. ft. state-of-the-art manufacturing facility located in Haines City, Florida.

Table of Contents

General Installation Guidelines

Pages 2-3

Delivery & Staging of Materials

Pages 4-5

Installing Aercon Block

Pages 6-9

Installing Aercon Vertical Wall Panels

Pages 10-15

Installing Aercon Horizontal Wall Panels

Pages 16-20

Installing Aercon Floor and Roof Panels

Pages 17-25

Contact Aercon Florida LLC

Pages 26-27

Nothing Outperforms AERCON!

Fast-Track Building Solutions



INSTALLATION GUIDELINES FOR AERCON PRODUCTS



CONSTRUCTION BENEFITS

- Fast and efficient panel installation reduces labor cost
- Modular components provide for ease of erection
- AERCON AAC puts your project on the fast track
- No reshoring accelerates finish trades
- No furring, insulation or drywall needed
- Workable like wood

Tremendous Benefits for Everyone

AAC building systems have been successfully developed and implemented for more than 65 years. They have been utilized in residential and commercial applications.

The short- and long-term benefits of these systems are realized by owners, developers, designers and contractors alike. The benefits are achieved by the various material properties and methods that are associated with the established AERCON approach to construction.

For the Owner

One of the main benefits of AERCON is safety. An owner using AERCON products creates a sound, functional and safe building. Another benefit of the AERCON system is versatility. AERCON can provide many architectural features that will enhance and project a unique architectural image for the building and its owner. AERCON construction is insect and termite proof. Therefore, the need for expensive insect and pest treatment as well as long term maintenance costs will be greatly reduced. To complete AERCON's concept of a great building system, the superior thermal properties associated with all of the AERCON products will translate into increased energy savings.

For the Developer

The cost savings realized when using AERCON products, mainly related to the shorter construction time, will be dramatic. The advantages of AERCON include low maintenance costs, good sound insulation and excellent thermal insulation. It easily meets hurricane and energy codes.

For the Designer

Creative designs cannot be realized without the use of a highly adaptable construction material. AERCON can be adapted to suit most architectural designs while still providing a simple construction system that can meet all load requirements.

For the Contractor

Buildings can be constructed quickly and safely using AERCON building systems. The product itself is lightweight; therefore easily handled.

AERCON's workability (e.g. anchoring, routing, and drilling characteristics) is well developed and can be easily performed. Typically, wall panel connections are installed with nails. AERCON material also produces less waste. By using the right combinations of AERCON products, productivity will be increased. AERCON will reduce the amount of time spent on job sites due to its ease of handling.

Conclusion

All these factors relate to cost, time and labor savings for the project. These factors epitomize AERCON's commitment to expediting construction, cost effectiveness and an aesthetically appealing building system.

Disclaimer: The information contained within this document shall be used as guidelines for workmanship and general construction practices for the installation of AERCON Products. This information should be recognized as recommendations and should be used with judgment. Implementation, interpretation and use of this document shall be the sole responsibility of the Installation Contractor.

For More Information Please Visit

<http://www.aerconaac.com/>



DELIVERY & STAGING OF MATERIALS

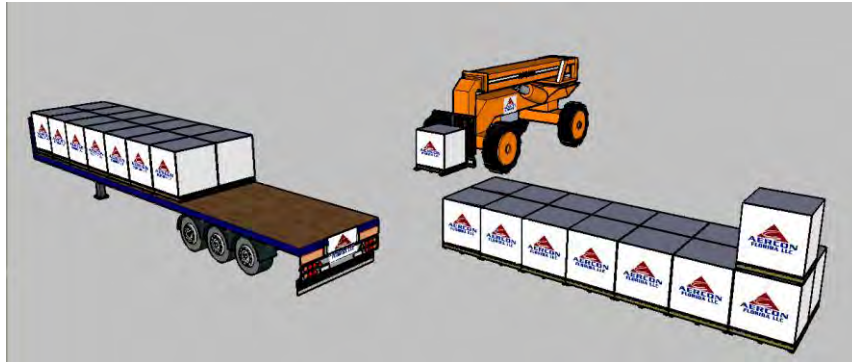

AERCON MATERIALS

Material Handling Procedures

Please read the following instructions to insure proper handling and installation of Autoclaved Aerated Concrete (AAC). Damage may occur if AAC is moved or handled several times.

For All AERCON Special Considerations For Construction Products

Deliver material far enough in advance of the installation start date so schedule will not be delayed.

Unload panels using pallet forks (either Unload panels using pallet forks (either forklift, nylon straps, slings or pallet fork on a crane cable). Consult your OSHA safety manual for "rigging" or other safety considerations.

Storage areas should be accessible to delivery trucks and convenient to material staging areas. If possible, drop-deliver the material right to the material staging areas.

Storage material should always be stored away from other construction activities on a flat-grade area that is not susceptible to standing water, erosion or settling.

In adverse weather conditions, keep the material covered and banded until ready for installation.

AERCON Panel Construction

Do not "shake-out" stored materials until they are ready to be installed. Excessive handling may cause damage. Set delivery schedule to match the erection sequence exactly.

Most chipped corners and edges can be repaired. If any reinforcing is visible, contact an authorized AERCON representative.

All damage must be repaired using an approved structural grade AERCON patching compound developed specifically for AERCON products.

Precast Autoclaved Aerated Concrete panels that have surface or minor cracks are usable, but contact an authorized AERCON representative when cracks continue completely through the panel.

Stored or staged materials should always be set on flat, load-bearing, stable grade on pallets or dunnage



Disclaimer: The information contained within this document shall be used as guidelines for workmanship and general construction practices for the installation of AERCON Products. This information should be recognized as recommendations and should be used with judgment. Implementation, interpretation and use of this document shall be the sole responsibility of the Installation Contractor.

AAC Masonry Products Leveling Course

Step 1 - Layout wall lines.

Lay out wall lines on building slab by control lines.

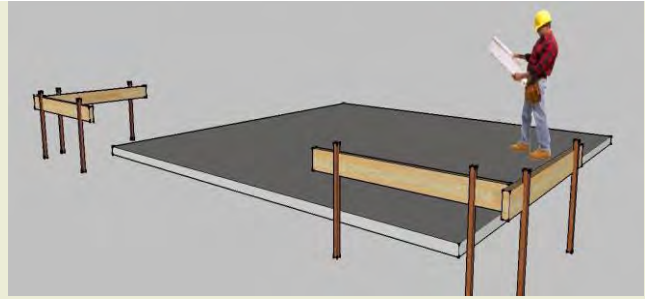

Step 2 -Start the leveling bed.

At the highest corner of the slab place a full width 1/2" deep sand-cement mortar joint using a masonry trowel (Mortar to be either Ready-Mix or 3:1 Sand: Portland Cement ratio or approved then-bed mortar).

Do not use thin-bed mortar or large grain mortar for the leveling bed joint.

If moisture and wicking is a problem, add water resistance mixture to sand-cement mortar

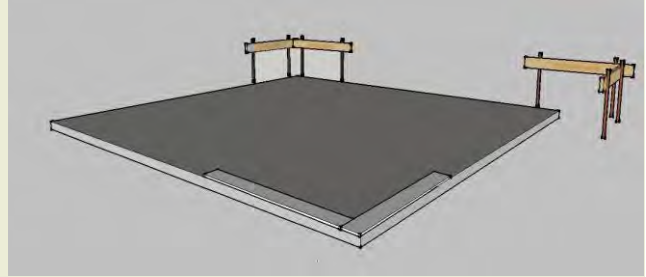

Step 3 - Set the first corner block.

Set the first corner block in the sand -cement mortar and adjust the joint as needed. To achieve the required height, lower or raise the block by tapping down with a rubber mallet or by adding additional mortar beneath.

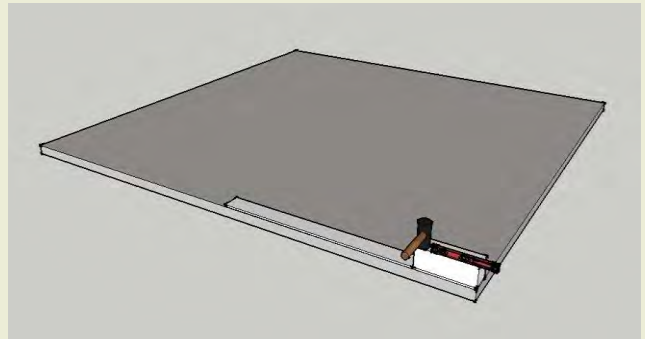

Step 4 - Mix thin-bed mortar.

Mix approved AAC thin-bed mortar in a clean mixing container (5-gallon bucket or pail) per manufacturer's directions. The consistency of the mixed thin-bed mortar should be such that it flows easily through the teeth of the notched trowel leaving the shape of the teeth in the mortar bed.

Thin-bed mortar droppings should not be used.

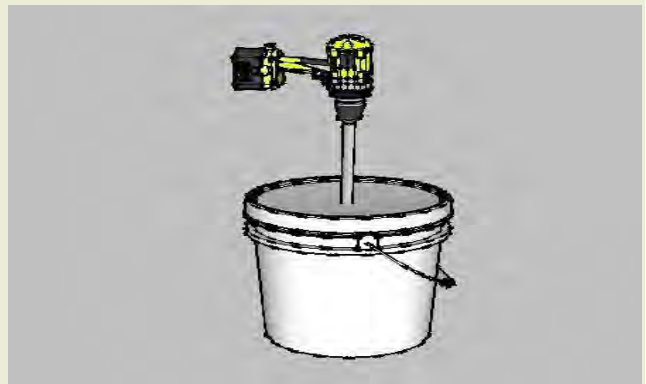

Step 5 - Set second corner block.

Set the second corner block adding thin-bed mortar to the head joint with the ¼ inch notched trowel.

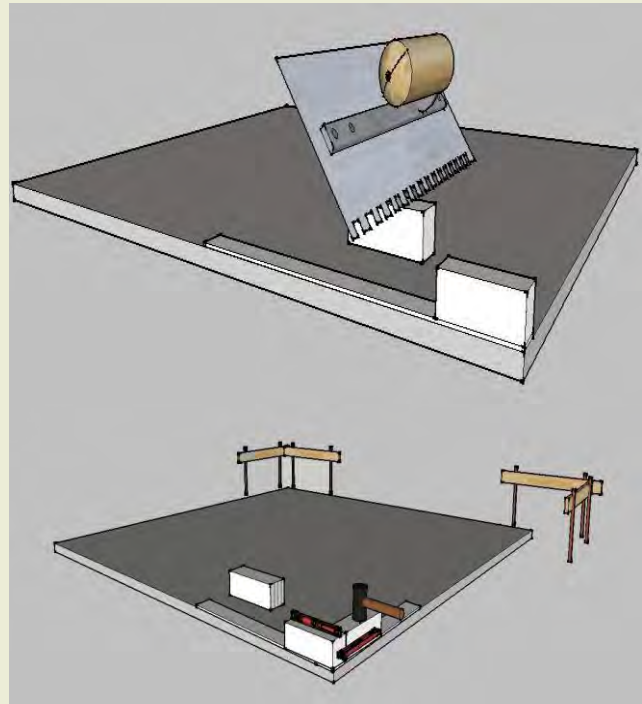

Step 6 – Repeat for additional corners.

Repeat subsequent steps for each corner using a builder's level to maintain an equal elevation. Triple check each lead corner in all three planes.

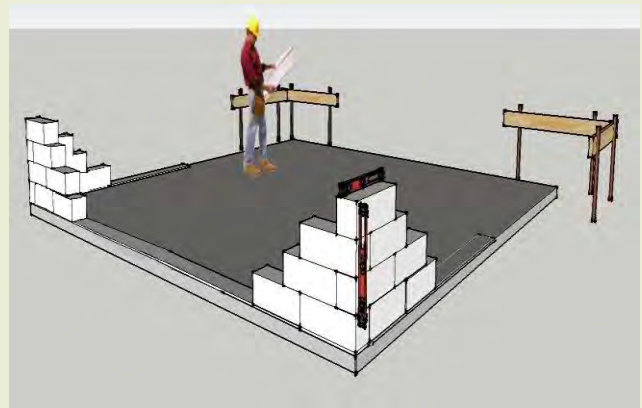

Step 7 - Fill-in completion of level course.

After building the lead corners, pull a string between corners to complete the leveling course. Sand-cement mortar should be used for the bed joint and thin-bed mortar for each head joint. Level across each block to insure a plumb wall.

Do not use sand-cement mortar for courses other than the leveling course.

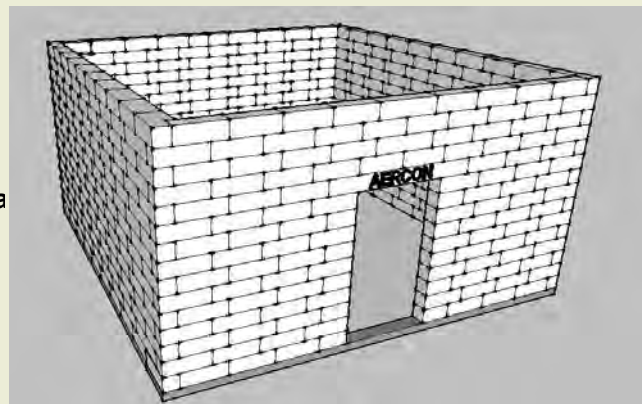

Step 8- Install lintels as required.

Install lintels with a minimum 8" bearing (overlap) where required

Lintels End bearing for lintels should normally be not less than 8". Where stresses under lintel bearing will exceed permissible values (e.g. under heavy concentrated loads), concrete spreaders or pad stones should be incorporated. Cold bridging at lintel positions can be avoided by the use of AAC in association with appropriate types of lintels. These allow the insulating properties of AAC blocks to be continuous across the wall face and can facilitate the placing of subsequent door and window fasteners. If multiple courses of U-Block are used, notching is required to allow concrete to get to the lowest course. Always pre-wet the u-block before pouring the grout.

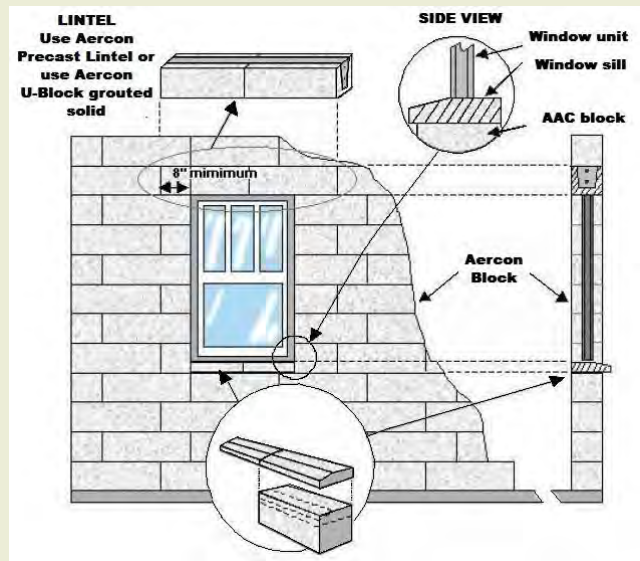

AAC Masonry Products Points To Check

Point 1

Leveling course must be level and plumb. Do not proceed to subsequent courses until leveling course has set sufficiently

Point 2

Blocks must be installed in a running bond with a 8" bearing (overlap). Lintels must be installed with a minimum 8" bearing (overlap).

Point 3

All head and bed joints must be solid with approved AAC thin-bed mortar for full adhesion. Do not tooth.



Disclaimer: The information contained within this document shall be used as guidelines for workmanship and general construction practices for the installation of AERCON Products. This information should be recognized as recommendations and should be used with judgment. Implementation, interpretation and use of this document shall be the sole responsibility of the Installation Contractor.

INSTALLING AERCON VERTICAL WALL PANELS



AERCON Vertical Wall Panels

Tools required for installation

There is a full-range of tools that are specially designed to assist in installing Aercon wall panels and increase productivity at the job site. Aercon installation will also require the following standard industry tools:



Step 1

Check panel layout of approved Aercon shop drawings and deliver panels to jobsite accordingly.



Step 2

Unload the bundles of panels in a proper manner using approved unloading gear. Protect the Aercon panels from rain and water saturation by leaving them on pallets and away from standing water. Eliminate excessive handling by storing Aercon panels nearest to where they will be installed. Protect the Aercon panels when traveling on uneven ground.



Step 3

Lay out wall lines on building slab by control lines as well as field verify all dimensions and openings.

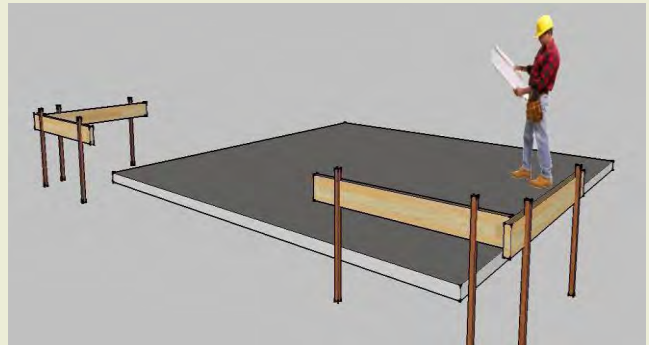

Step 4

Attach wood straight-edge (2x4) to the slab so that it is flush to the inside wall line of the panel. This will act as a guide to install the Aercon panels.

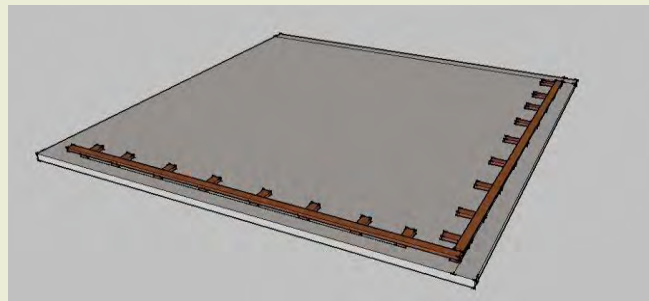

Step 5

Prior to setting Aercon panels, mobilize the job site crane to an optimum location to avoid excessive downtime from moving it too often. Attach approved lifting gear to the crane cable and begin installation.

Erection should start from a corner taking care to fit additional Aercon panels tightly together. The wall panel is lifted by using a WKV wall panel clamp that is attached to the panel and lowering it onto the Aercon large-grain mortar. See step 13 for alternative lifting device.

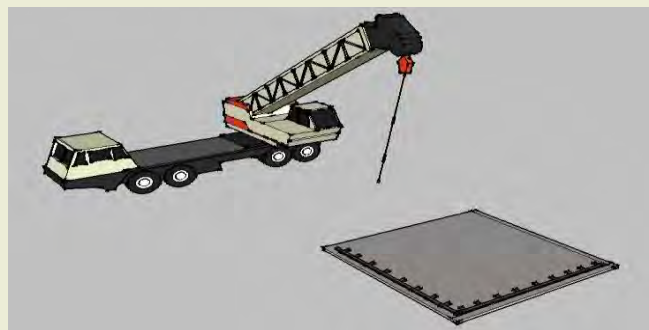

Step 6

At the highest corner of the slab place a full width of Aercon large-grain mortar using a notched masonry trowel. Use plastic shims as needed, along with Large-grain mortar to correctly level the slab or footing to the correct height. Do not use thin-bed only large-grain mortar to level slab of footing.

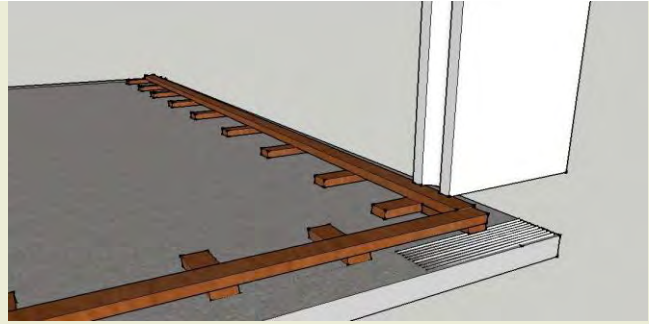

Step 7

As soon as the panel is adjusted to being plumb and level, attach temporary bracing from the upper third of the panel down to the floor. Follow OSHA guidelines for temporary bracing requirements.

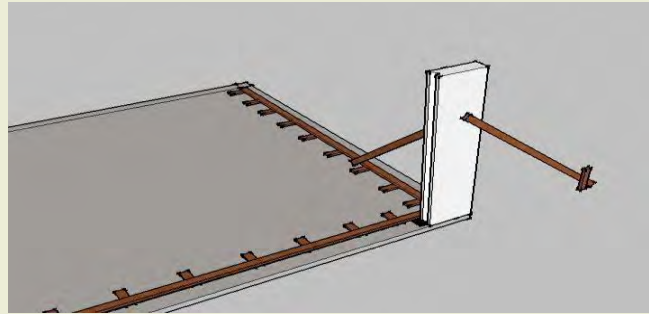

Step 8

Mix the Aercon thin-bed mortar in a clean mixing container (5 gallon bucket or pail) per manufacturer's directions. The consistency of the mixed thin-bed mortar should be such that it flows easily through the teeth of the notched trowel leaving the shape of the teeth in the mortar bed. Thin-bed mortar droppings should not be used. Before mixing each new batch, wash out the bucket or pail to prevent any old thin-bed mortar from accelerating the drying time of the new mix.



Step 9

Set the second corner panel tight against the previously set first corner panel using the following actions

First

Place thin-bed mortar in between the head joints of the vertical panels using a notched trowel. Either place thin bed mortar on the panel to be installed while it is in the resting position on the ground or place thin-bed mortar on the previously set panel prior to the next one being installed.

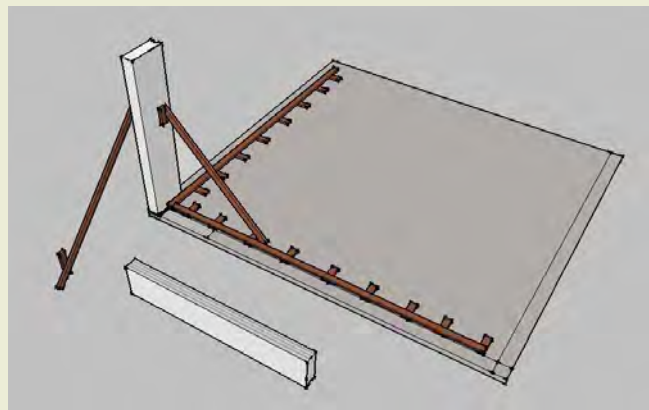

Second

Lifting gear installation instructions. Always check lifting device using the calibration unit that is paired with the lifting device, before starting each day and after each break the crew takes. Move the clamp to the end of the wall panel to be lifted. Open the clamp sufficiently, depending on the thickness of the panel, by turning the hand wheel counter clockwise. Rotate the clamp 90 degrees on the handle so that the jaws of the clamp may be placed in the center of the wall panel. Press the inner side of the clamp fully against the wall panel. Apply pressure to the clamp by turning the hand wheel of the clamp clockwise until there is a click and the green windows are visible (do not turn any further). Carefully hoist the wall panel up and maneuver it into the place where it is to be installed. When the wall panel has been positioned correctly, the clamp can be released by turning the hand wheel counterclockwise. The vertical joint between each panel should be skimmed and then scraped while waiting for the next panel.

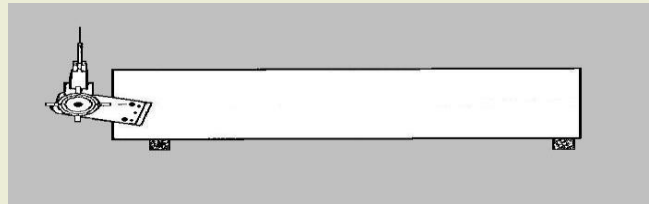
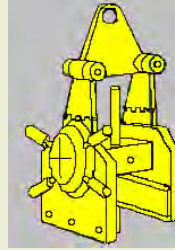

Third

Lift panel and install it by moving it laterally as close to the previously set panel as possible and then lowering it down onto the large-grain mortar.

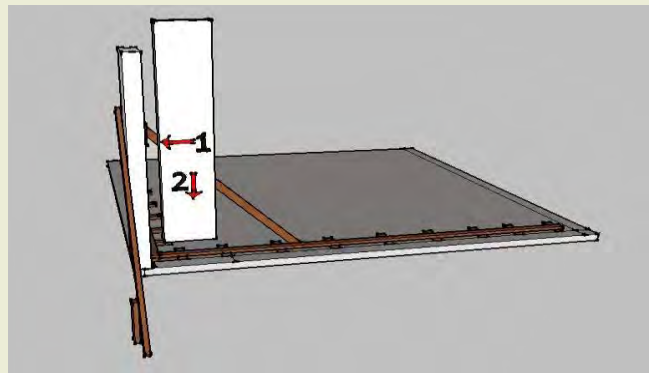

Step 10

Attach Helifix driver to a rotary percussion drill or to a hammer drill as per manufacturer's instructions and load anchor. At corner, install "Helifix" anchors through the face of the side of one panel into the end of the panel that is in the perpendicular direction. Center the Helifix anchor so that it penetrates through the middle of the perpendicular panel. Install as noted on Aercon approved shop drawing.

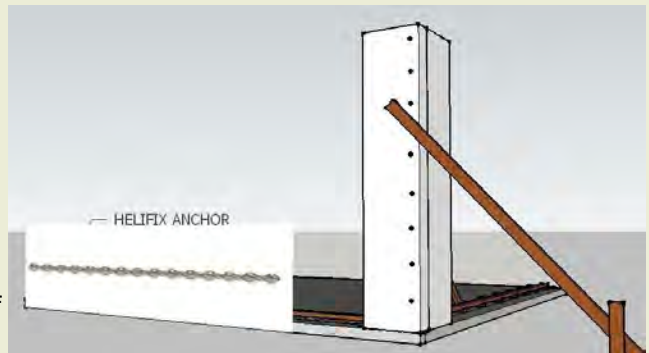

Hammer Drill (SDS type chuck)

Step 11

Install galvanized corrugated nails within vertical joints one at 2'-0" from the top of wall and one at 2'-0" from the bottom of wall vertically or as required Using a hammer (more can be used as needed)

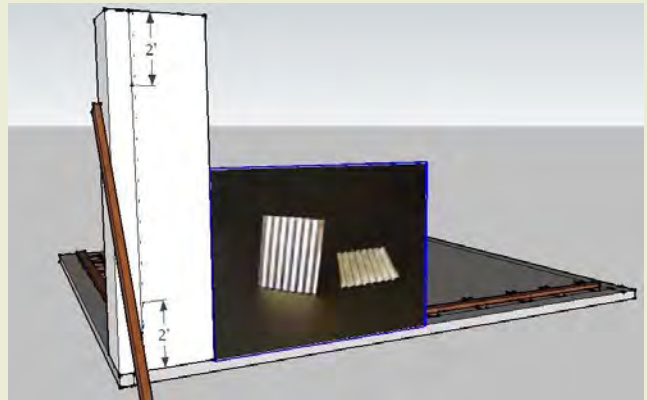

Step 12

Drill and epoxy reinforcing steel dowels into existing slab at the center of the radius of the Aercon panel. Continue to install rebar at all locations according to structural drawing.

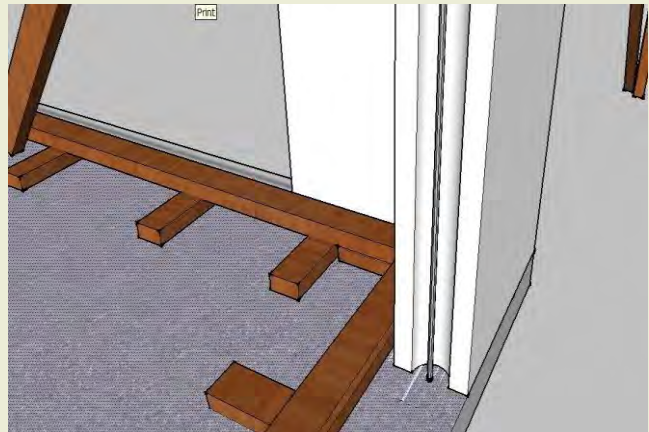

Step 13

Repeat step 9 for subsequent panels. Make sure a tight joint is present between panels. Use Aercon thin-bed mortar for vertical panel joints. Brace walls as necessary. Minimum bracing should be every three (3) panels.

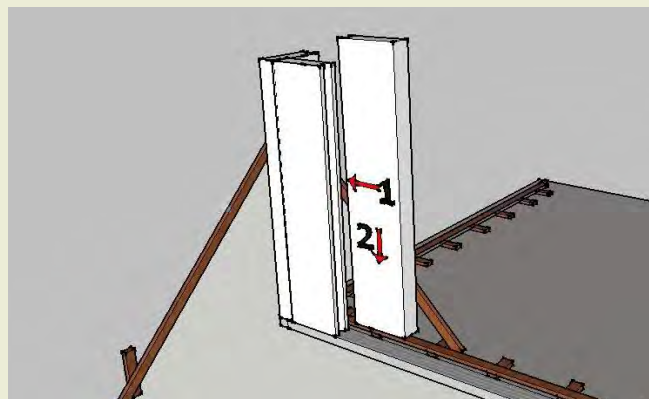

Step 14

Install reinforcing steel then pre-wet core and then place concrete (flowable grout) within vertical core according to drawings. Lightly tap rebar to help consolidate the grout and then screed off excess.

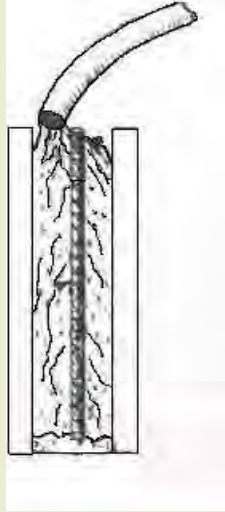

Disclaimer: The information contained within this document shall be used as guidelines for workmanship and general construction practices for the installation of AERCON Products. This information should be recognized as recommendations and should be used with judgment. Implementation, interpretation and use of this document shall be the sole responsibility of the Installation Contractor.

Do not use a pencil vibrator as it will cause the panels face to crack.

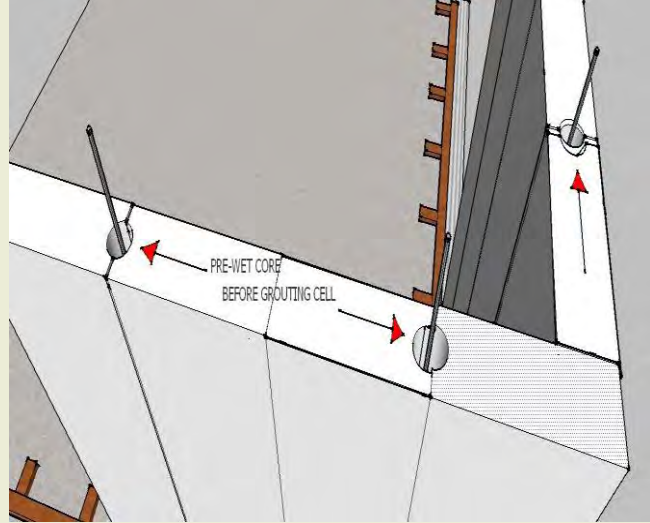

INSTALLING AERCON HORIZONTAL WALL PANELS



Tools Required For Installation Of AERCON Horizontal Wall Panels

Tools

- used for handling and installation of Autoclaved Aerated Concrete – AAC

There are a full-range of tools that are specially designed to assist in installing AERCON wall panels and increase productivity at the job site.

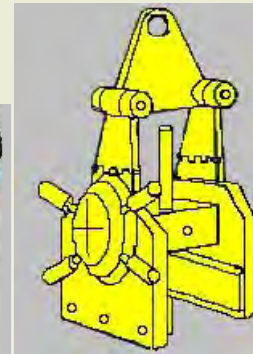
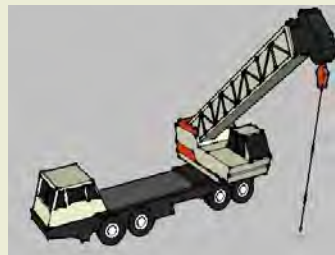

AERCON installation will also require the following standard industry tools.

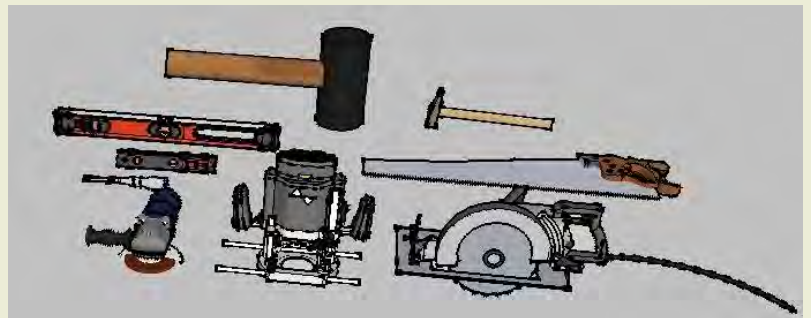

AERCON Horizontal Wall Panels Laying Panels

Proper installation of Aercon Horizontal Wall Panels should include a 1" step down in the Slab where the panel will sit.

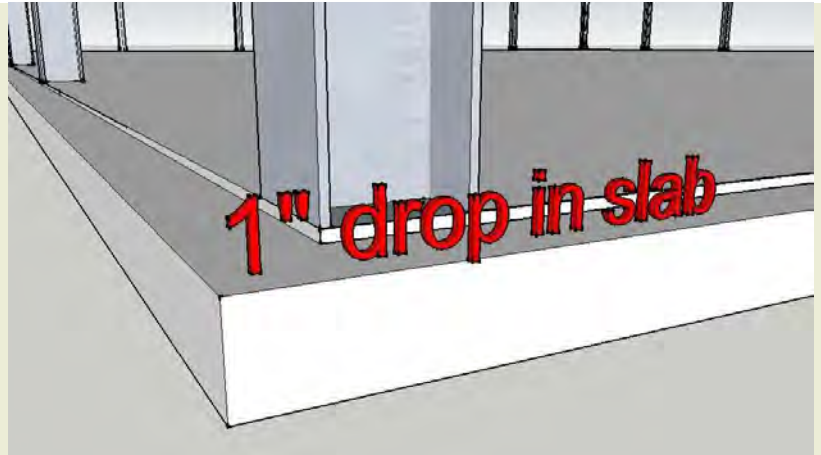

Step 1 - Check plumbness of column line

- Check column line layout and plumbness. Verify layout is within industry standards. Using a level and transit, establish elevations onto the columns that will act as a control line for setting the first AERCON panels.

If need, apply approved waterproofing agent underneath panel wall lines per Architect/Owner decision, guidelines.

Alert General Contractor To Column Line Problems And Correct Before Proceeding.

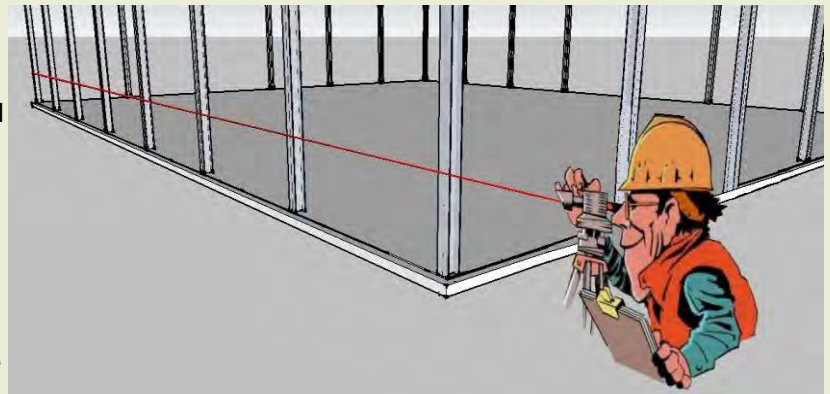

Step 2 - Place first panel

- Measure down from the benchmark elevations to establish the highest point on the slab. Install the first panel, tongue side up, at the highest point of the slab or stem wall, on top of pre-leveled shims to establish a minimum depth of setting bed. Place sand-cement mortar joint of at least 1/2" using a conventional masonry trowel (mortar to be either Ready-mix or 3:1 Sand: Portland Cement ratio or approved AERCON large grain mortar) along wall line in between plastic shims.

Other bays will require adjusting the depth of the setting bed prior to installing the first panel.

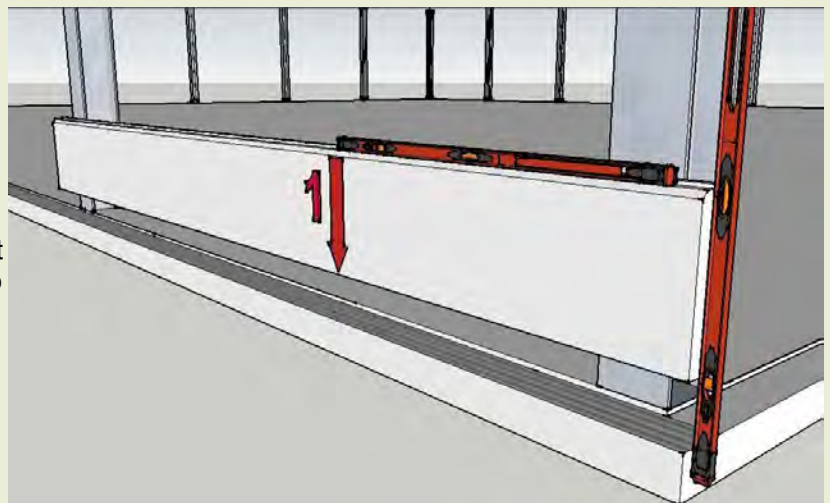

Step 3 - Notch each end of the panel

-Notch ends of each panel with a grinder/saw to receive anchors.



Step 4- Place and secure anchor

- Place anchor according to AERCON shop drawings and specifications. Place the wall plate anchor into the notch at each end of the panel. Using a hammer drive the tube nails through all of the nail holes to secure. This must be accomplished before the next panel is set.

1. AERCON Horizontal Wall Panel
2. Steel Angle Attached to Column
3. Steel Column
4. Wall Plate Anchor
5. Trim Tongue For Wall Plate Anchor Installation
6. AERCON Horizontal Wall Panel
7. Expansion Joint

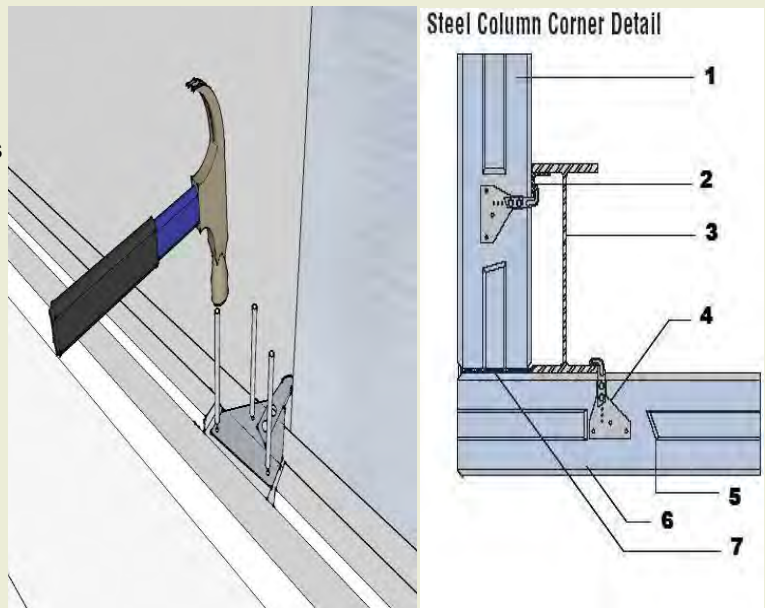

Step 5 - Before setting the next panel

-Release panel clamp and remove all dust and particles from the top of the installed panel and the bottom of the next panel with a brush.

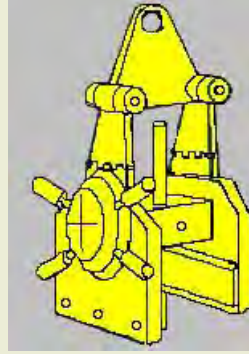

Step 6 - Install the 2nd, 3rd and 4th panel

-Align the ends and groove of the second panel with the ends and tongue of the first panel and set into place. Repeat Steps 1 - 5 for the subsequent panels in accordance with AERCON shop drawings.

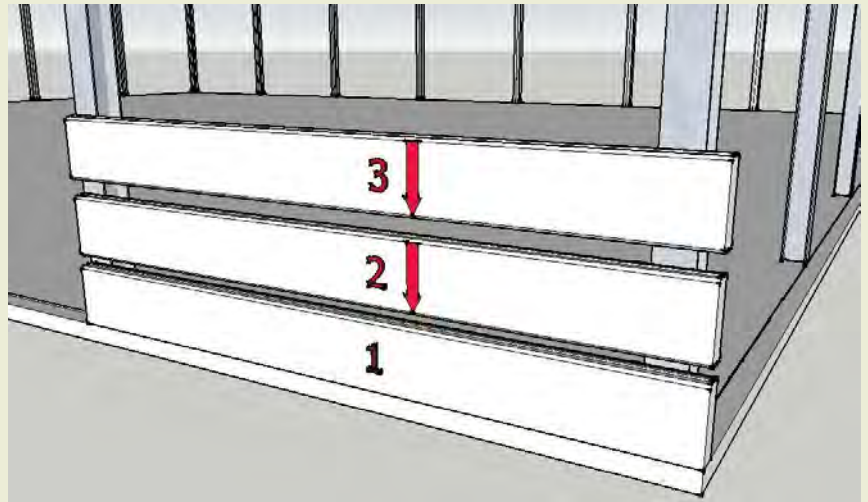

Step 7 - Continue setting the panel

-After panels are installed, clean all horizontal and vertical joints with a brush and apply exterior joint sealants in accordance with specifications and/or shop drawings.

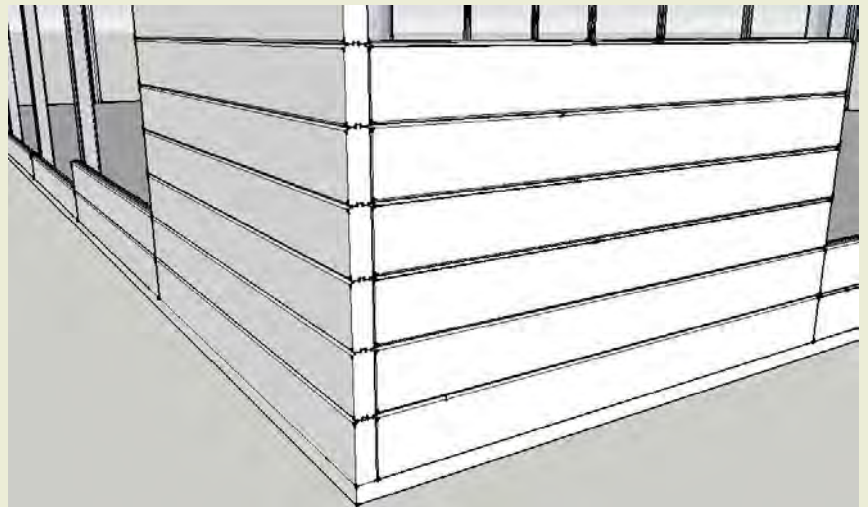

Step 7 – Expansion or Control Joints

-Make sure that all details are followed according to Aercon Shop Drawings.

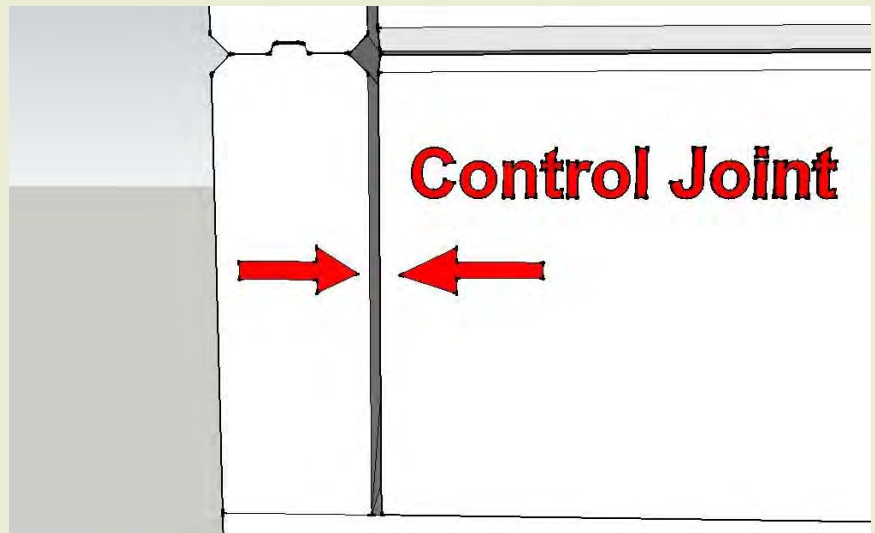

AAC Horizontals Points To Check

Point 1

Supporting columns must be plumb, level and within linear building line tolerances.

Point 2

Protect the panels from rainwater saturation by leaving them on pallets and away from standing water.

Point 3

Set panels with tongue side up and follow specifications and shop drawings for placement expansion joints and all other details.

Point 4

Panel(s) must lay flush against face the of column or steel shim plates. Failure To Adhere To These Proper Installation Procedures Will Render Warranty Null And Void.

Disclaimer: The information contained within this document shall be used as guidelines for workmanship and general construction practices for the installation of AERCON Products. This information should be recognized as recommendations and should be used with judgment. Implementation, interpretation and use of this document shall be the sole responsibility of the Installation Contractor.

INSTALLING AERCON FLOOR & ROOF PANELS



AERCON floor and roof panels are installed using a crane and clamp.

AAC Precast Floor Panels Material Handling Procedures

There are a full range of tools that are specially designed to assist in installing Floor Panels and increase productivity at the job site. AAC masonry installation will also require the following standard masonry tools.

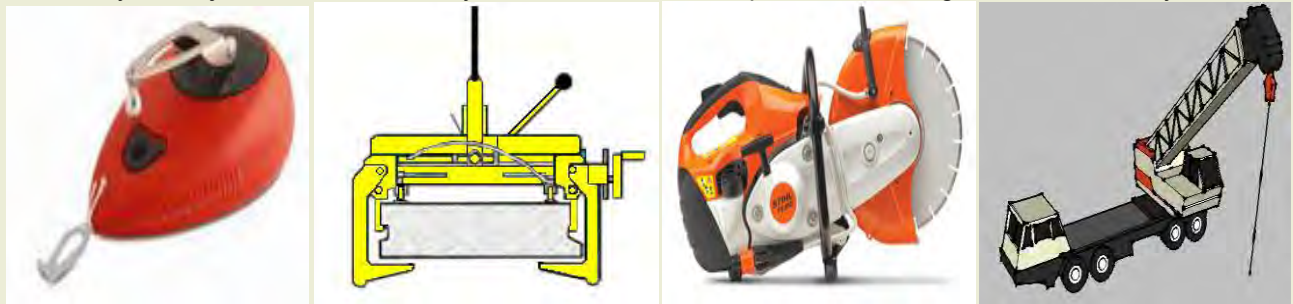

AAC Precast Floor Panels Installing Panels

Step 1

Unload bundles of panels in proper manner using approved unloading gear. If panels must be stored, place them in a clean area without standing water that is close to where work will begin.

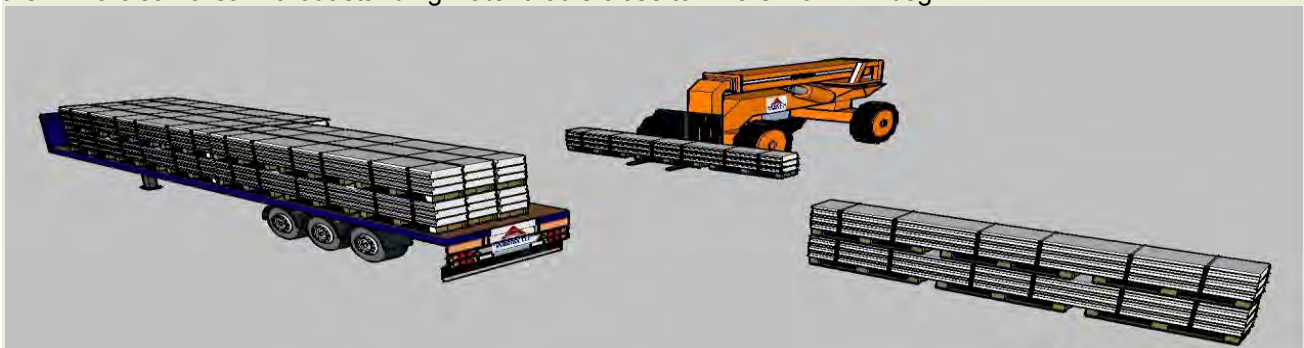

Step 2

Layout Bearing Lines Using a tape measure, layout and chalk the bearing (bearing area is represented by red shaded areas 2 ½" minimum to 3" maximum) lines on top of walls using detail drawings approved for construction. Make sure all bearing, top-of-wall surfaces are level..

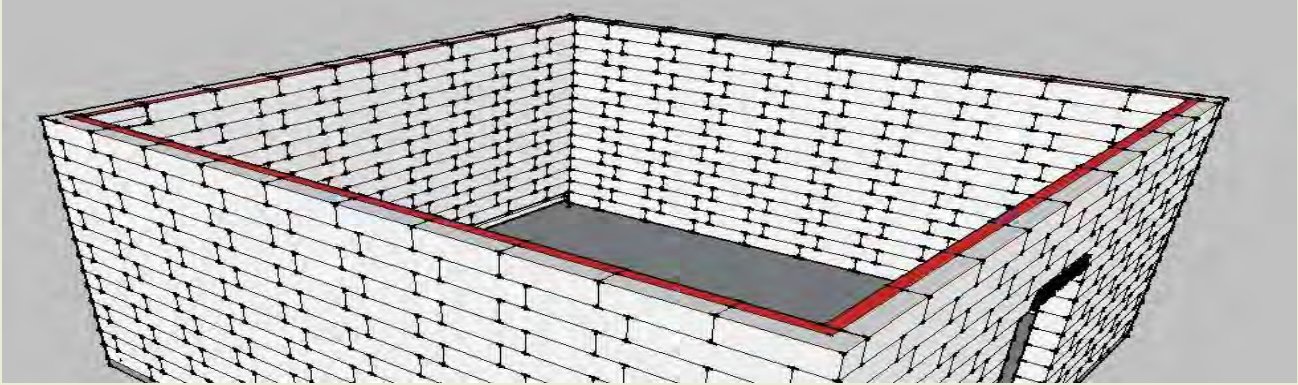

Step 3

Attach Panel Lifting Gear. Place panels in a flat position with topside up. Attach approved panel lifting gear (floor clamp) to the first panel. Be sure to observe manufacturer's proper attachment procedures and safety guidelines.

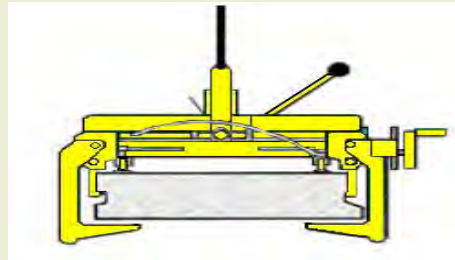

Step 4

The first floor panel is lifted, placed and adjusted into exact alignment along bearing lines. A person is required to steady and guide each end of the panel. Note the edge profiling and mark number of the panel, and install accordingly. Maintain minimum bearing according to drawings. Bearing pads should be placed on top of wall where the bearing of the floor panel will occur. Start the first panel with the groove facing the direction you will be laying the panels in or you will not be able to release the clamp when installing the next panel

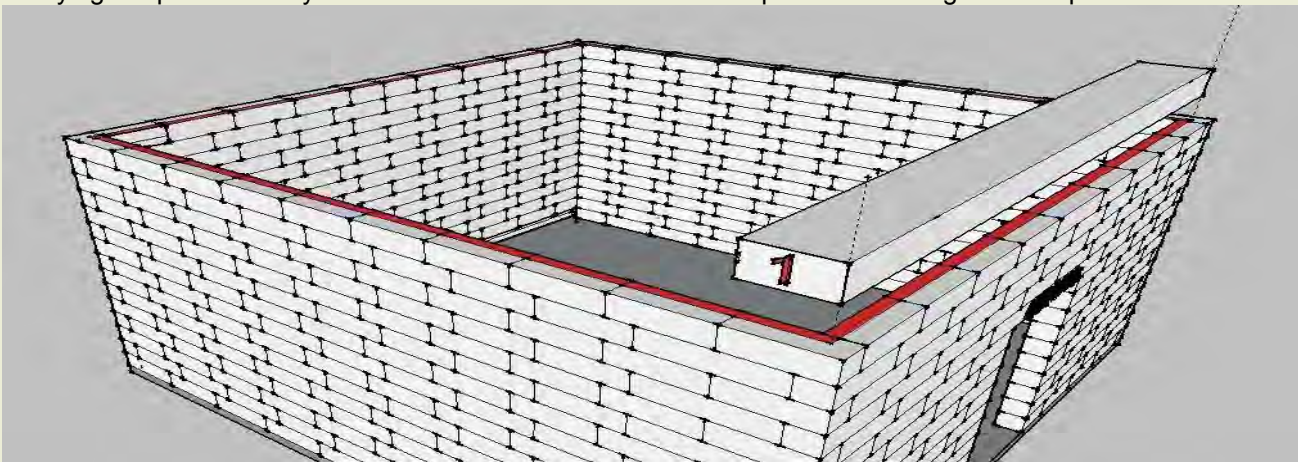

Step 5

Repeat For Remaining Panels. Lay the remaining panels ensuring that each one is seated firmly beside the preceding one.

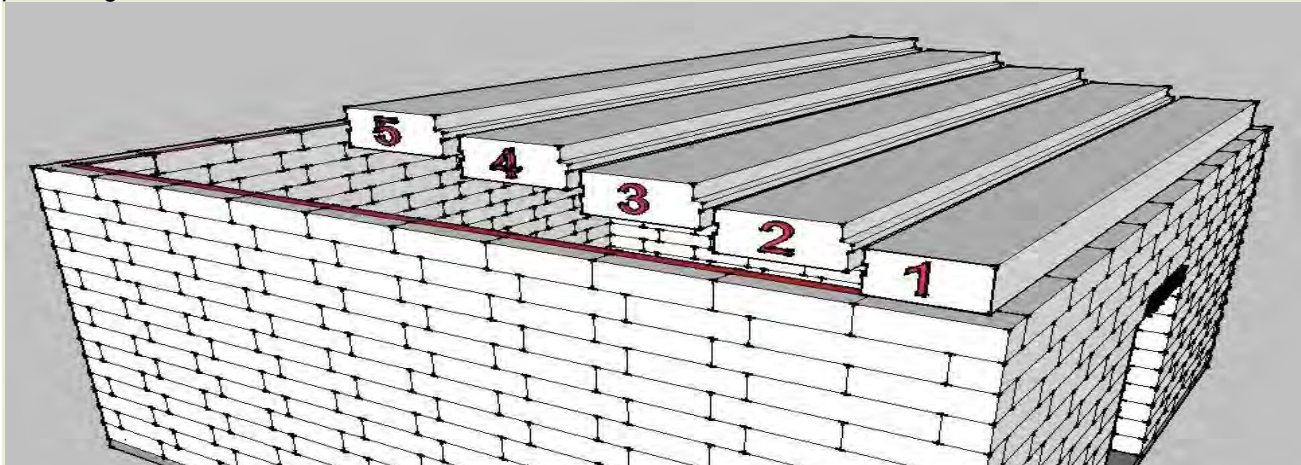

Step 6

Placing Last Panel. The correct lifting gear will greatly assist placement of the last panel. Special procedures may be required if other lifting devices are used (i.e. slings or ropes).

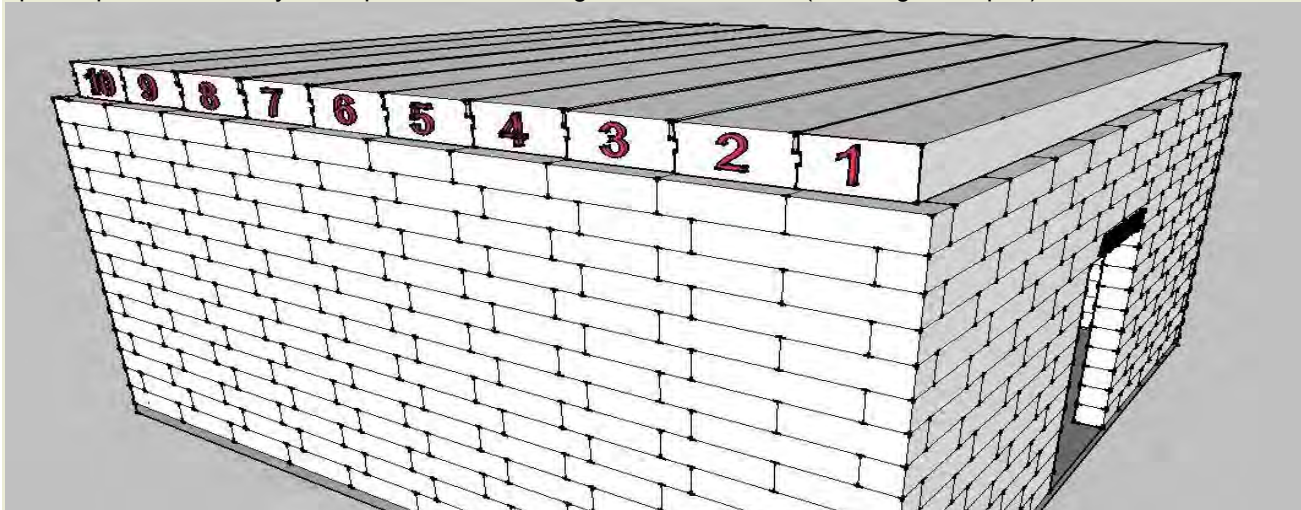

AAC Precast Floor Panels Filling Joints

Step 1

Set plywood (minimum 3/4") around exterior perimeter for formwork for all ring beams shown on detailed drawings. As an alternative Screen Block minimum 2" forms can be used as the exterior form.

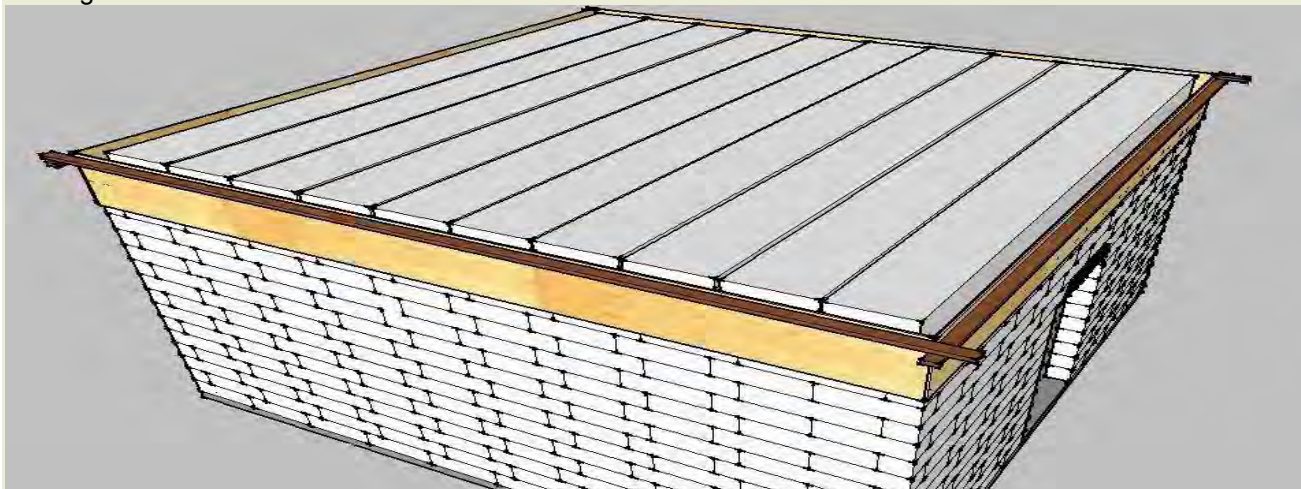

Step 2

Install reinforcing steel in panel joints, ring beams, and lintels according to detail drawings. Make sure all rebar is in correct position before concrete is placed. Tie wire or chairs may be used to hold rebar at correct heights. Hangar wire for suspended ceilings may be installed through floor panel joints at this time.

- #1 Reinforcing Bar in Grout Filled Key Joint
- #2 AERCON Roof Panel, AERCON Block Wall or Vertical Wall Panel
- #3 Bond Beam w/Reinforcing Bars or Key way 2 Layers of Felt Paper
- #4 Block Wall or Vertical Wall Panel Dowel (Drill and Epoxy as Required)
- #5 Dowel (Drill and Epoxy as Required)
- #6 2 Layers of Felt Paper

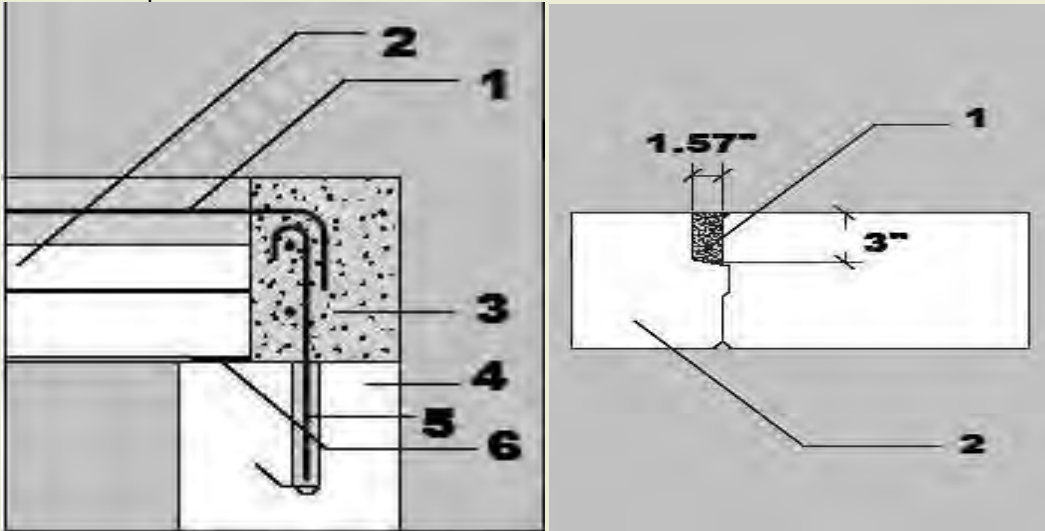

Step 3

Fill joints with grout. Firmly tamp into all joints, screed off excess and finish. A Pencil Vibrator may be used in the ring beam only (not down cells) Tap the rebar lightly to consolidate the grout.



AAC Precast Floor Panels Panel Penetration Guideline

Panels with holes must be designed to have sufficient reinforcement. **DO NOT CUT OR PENETRATE PANELS WITHOUT APPROVAL OF AN AERCON ENGINEER. USLESS SHOWN ON APPROVED AERCON SHOP DRAWINGS**

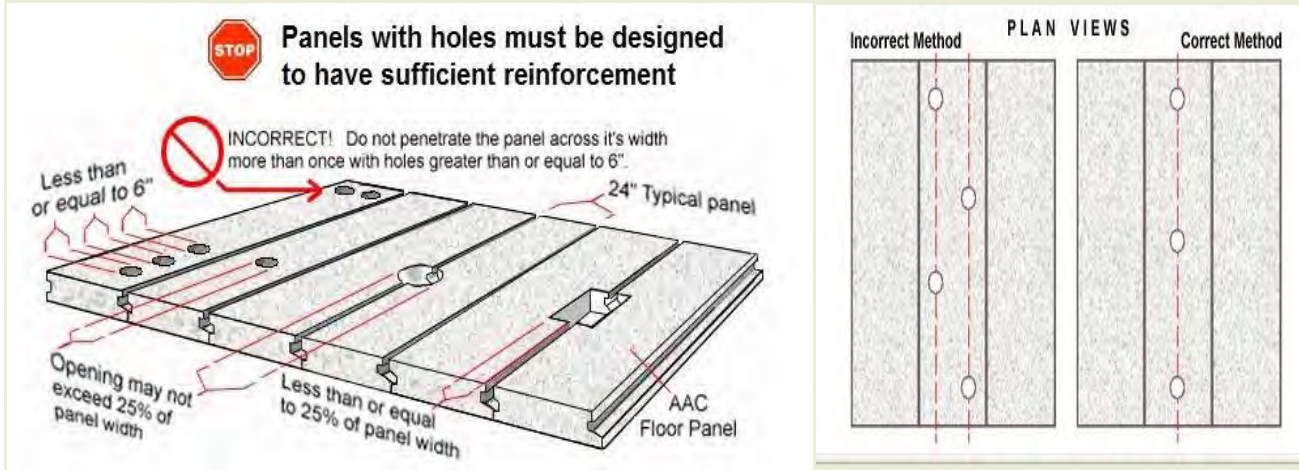

AAC Precast Floor Panels Points To Check

Point 1

Supporting walls must be level and plumb.

Point 2

Minimum bearing as shown in AERCON drawings must be maintained. Bearing Felt should be used.

Point 3

Concrete poured into joints must completely cover all reinforcement and be finished smooth.

Point 4

Do not cut or modify a panel without first checking with an AERCON engineer. Observe all guidelines for coring and other floor penetrations. Never cut the floor panels to shorten them without approval from an AERCON engineer.

Disclaimer: The information contained within this document shall be used as guidelines for workmanship and general construction practices for the installation of AERCON Products. This information should be recognized as recommendations and should be used with judgment. Implementation, interpretation and use of this document shall be the sole responsibility of the Installation Contractor.

Nothing Outperforms AERCON!

Fast-Track Building Solutions



AERCON FLORIDA LLC CONTACT INFORMATION



AERCON's 100,000 sq. ft. state-of-the-art manufacturing facility located in Haines City, Florida.

AERCON

3701 CR 544 East
Haines City, FL 33844
863-422-6360
toll free: 800-830-3171 <http://www.aerconaac.com/>

AERCON General Manager

Mike Quaka
863-422-6360
Email Address: mquaka@aerconaac.com

Area Sales

Mike McCormick
863-422-6360
863.738.1010 cell
Email Address: Mikemc@aerconaac.com
Florida & Northeast Sales Manager

Nick Porter

Midwest & Southeast Sales Manager
821-202-0306 cell
Email Address: nporter@aerconaac.com

Robert Bruckner

Regional Sales Manager
Texas, Oklahoma, New Mexico
Toll Free 800-830-3171
214-869-2699 cell
Email Address: rbruckner@aerconaac.com

Brian Tully

Manager of Technical Services
863-422-6360

Email btully@erconae.com

Mark Herning

Technical Services Adviser
863-422-6360

Email mark.herning@erconae.com