

IV. Fire Resistance



Unaffected by the industrial fire that destroyed an adjacent wing, a surviving roof serves as a platform for firemen fighting the blaze. The aerated concrete demising wall protected the remaining portion of the building, enabling it to maintain its structural integrity.

- | | |
|--|-------------------|
| A. General | Page IV-2 |
| B. Fire Rated Wall Systems | Page IV-4 |
| C. Fire Rated Floor and Roof Systems | Page IV-8 |
| D. Fire Rated Joint Systems | Page IV-10 |
| E. Fire Rated Through-Penetration Systems | Page IV-11 |

A. General

AERCON products are non-combustible. So in the case of fire, AERCON will help prevent the spread of the fire to other rooms. When exposed to a fire, no toxic gases or vapors are emitted from AERCON products.

AERCON systems such as interior and exterior walls, and floor and roof panels provide tremendous fire rated assemblies in all types of buildings. Single-family and multifamily; townhouses; commercial, public and industrial buildings all benefit from the extraordinary fire ratings provided by AERCON products. A unique property of AERCON is that it contains water in crystalline

form, which acts as a heat sink, absorbing heat and changing into steam. AERCON's porous structure allows this steam to escape without causing surface spalling.

The following sections describe the numerous and diverse systems which can be used in fire rated applications to provide superb protection.

AERCON systems can be constructed using blocks, panels or a combination of products. Since these are solid elements with very simple connection details, the ease of construction helps to ensure a monolithic, highly fire-resistant assembly.

For the specific details and requirements of each system that is available, please see the referenced document. (Access to the UL references is currently available through their web site at www.ul.com. From their home page, select "Certifications" and search by company name: "AERCON".)

Walls, Floors and Roof Systems

Type of Element	Fire Resistance Rating	Min Thk of AERCON	Reference
Block Wall - Load Bearing	4 hr	6" Nominal	UL U919
Block Wall - Non-load Bearing	4 hr	4" Nominal	UL U919
Block Wall - Non-load Bearing	2 hr	3" Nominal	UL Engrg Letter
Wall Panel - Load Bearing	4 hr	6" Nominal	UL U920
Wall Panel - Non-load Bearing	4 hr	6" Nominal	UL U920
Wall Panel - T&G Non-load Bearing	4 hr	8" Nominal	UL Engrg Letter
Wall Partition - Non-load Bearing	3 hr	4" Nominal	ASTM E 119
Floor & Roof Panels	4 hr	6" Nominal	UL K909 & P932
Attached to Non-load Bearing Studs	2, 3, 4 hr	See Graphics	
Attached to Load Bearing Studs	1, 1-1/2, 2 hr	See Graphics	
Steel Column Protection	4 hr	4" Block or 8" Panel	UL X901

Through-Penetration Systems

	F Rating	T Rating	UL Number
Single Commodity	4	0	C-BJ-1037
Two Commodities	4	0	W-J-8009
Multiple Commodities	3	0	C-BJ-8010

Joint Systems

	Rating	UL System Number
Floor-to-Floor Joint	3 hr	FF-D-0018 & FF-D-0020
	2 hr	FF-D-0017
	1 1/2 hr	FF-D-0019
Floor-to-Wall Joint	3 hr	FW-D-0013 & FW-D-0015
	2 hr	FW-D-0012
	1 1/2 hr	FW-D-0014
Head of Wall Joint	3 hr	HW-D-0166 & HW-D-0177
Wall-to-Wall Joint	3 hr	WW-D-0023 & WW-D-0024

B. Fire Rated Wall Systems

Due to their exceptional performance when exposed to fire, AERCON products are the ideal solution for a multitude of superstructures and interior spaces that require a fire rating. Whether it's blocks or panels, AERCON can be used as fire separation walls between townhouses, condominiums, apartments and other multifamily dwellings. AERCON is also appropriate for hotels, motels, dormitories, assisted-living facilities, hospitals, prisons, jails, detention centers, schools, movie the-

atres, exit corridors, shaft walls, and stairwell walls. Industrial uses include electrical rooms, mechanical rooms, computer rooms, communications equipment rooms, flammable materials storage, document storage, warehouses, laundry rooms, boiler rooms, maintenance shops, emergency generator rooms, production control rooms, sprinkler control rooms and incinerator rooms.

AERCON products can be used as the primary load resisting

structural system in addition to being used as cladding to increase the fire rating of stud walls and to protect other materials such as structural steel.

Load bearing or non-load bearing; interior or exterior; single-story or multi-story; if you have a fire hazard, AERCON can provide a system to contain it. Use AERCON to restrict a fire from spreading or to protect valuables from an external fire. ***When safety is an issue, AERCON takes the heat.***

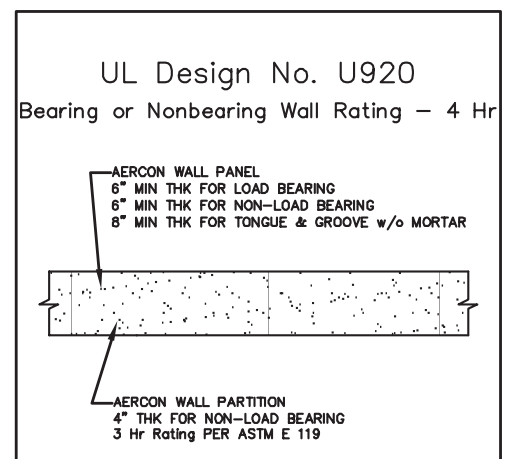
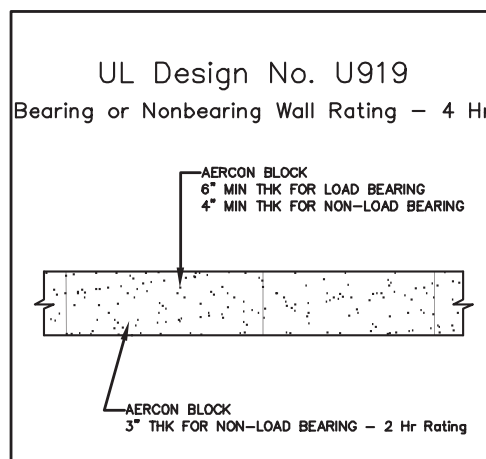

UL Design No. U206
Bearing Wall Rating - 2 or 1 Hr

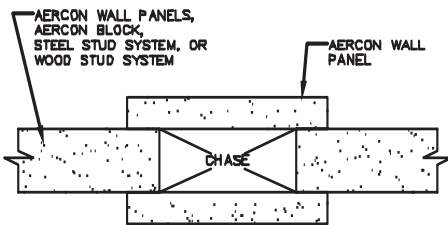

UL Design No. X901
Rating - 4 Hr

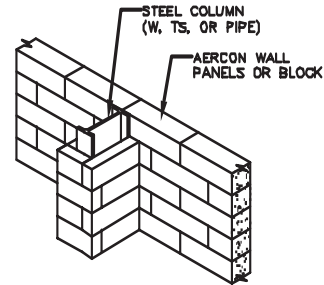

UL Design No. U205
Nonbearing Wall Rating - 4 Hr
Bearing Wall Rating - 2 Hr

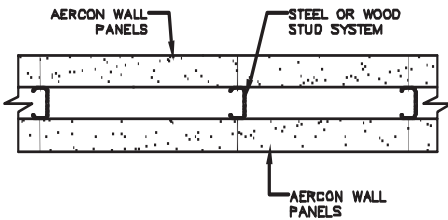

UL Design No. U208
Nonbearing Wall Rating - 4, 3, or 2 Hr

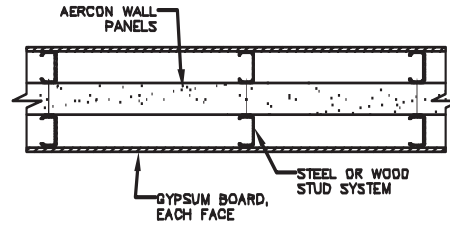

UL Design No. U207
Bearing Wall Rating - 2, 1 1/2 or 1 Hr

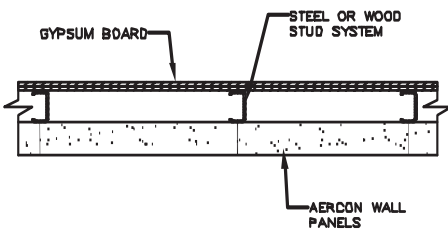

UL Design No. V420
Bearing or Nonbearing Wall Rating - 2 Hr

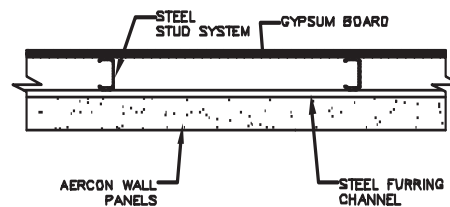

AERCON Block Wall - 4 Hour Fire Rating (ANSI/UL 263)

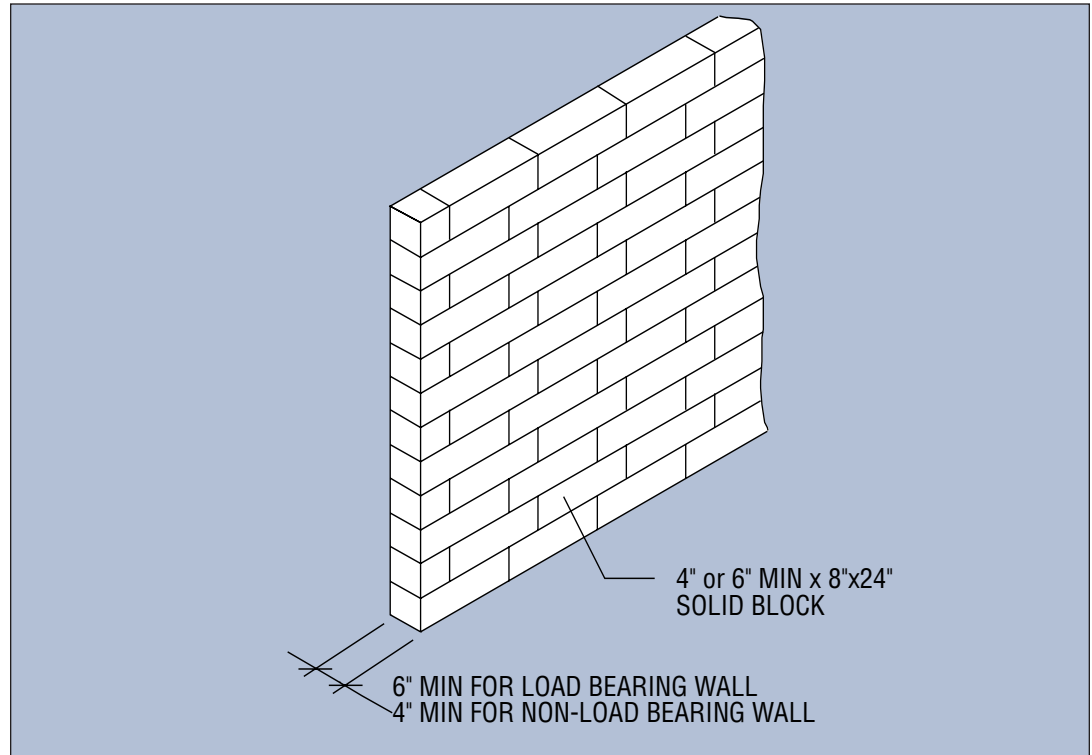

Fire Test Wall Temperatures for 8" Load Bearing Block Wall (ANSI/UL 263)

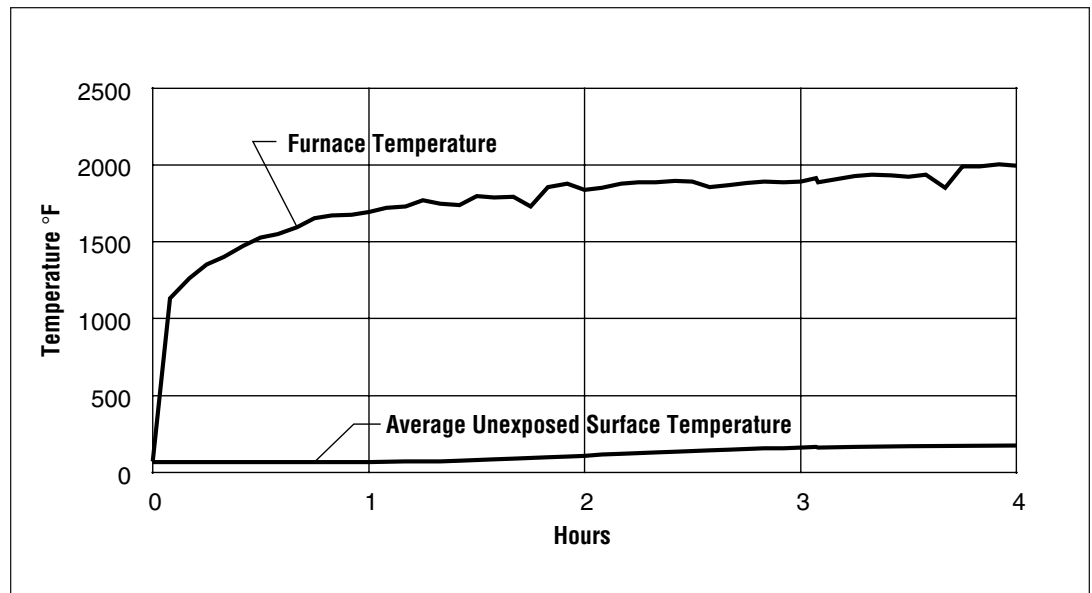

AERCON Interior Wall Partitions - 3 Hour Fire Rating (ASTM E 119)

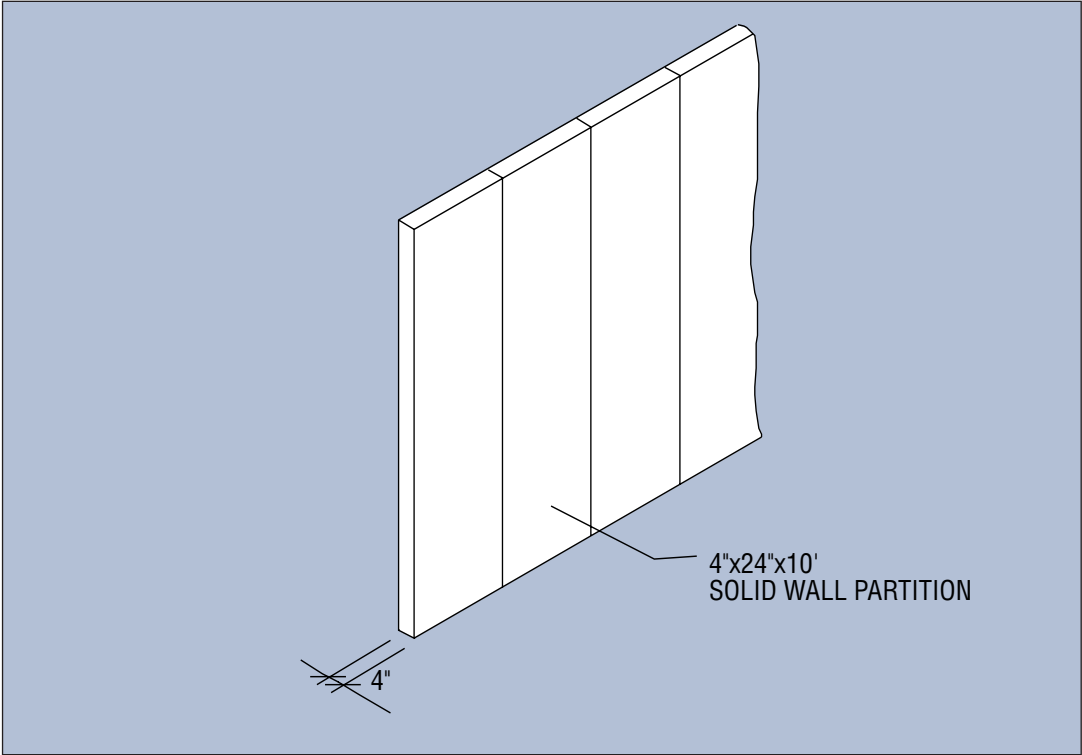

Fire Test Wall Temperatures for 4" Wall Partitions (ASTM E 119)

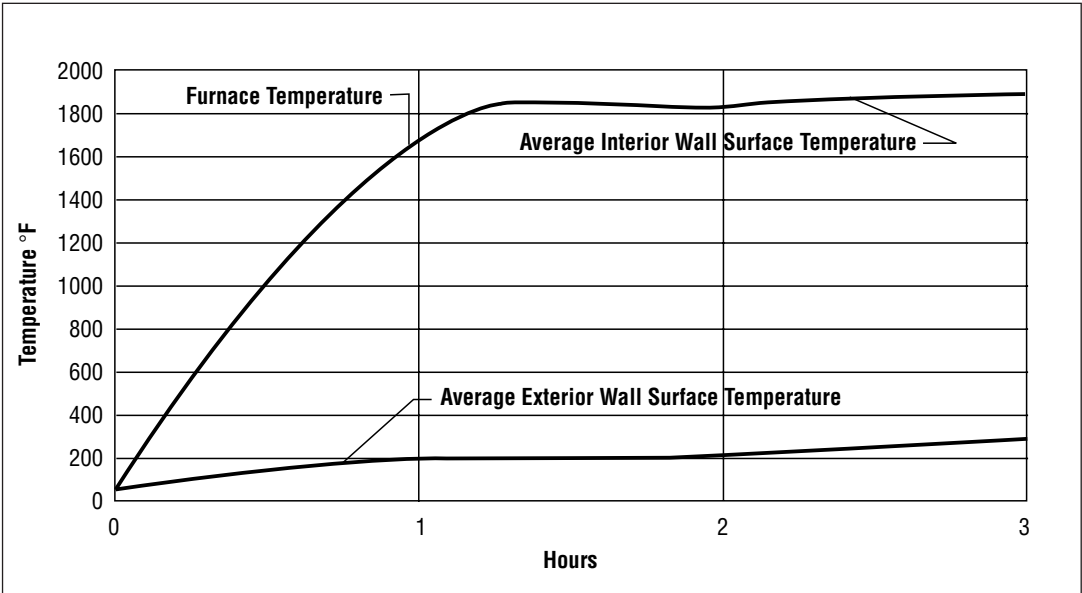

C. Fire Rated Floor and Roof Systems

In multi-story construction, AERCON floor panels are a multi-functional element. In addition to serving as the structural floor system, AERCON floor panels also provide any fire protection that may be required. The integral fire rating of AERCON floor panels eliminates the need for any ancillary materials or coatings to achieve a fire resistant assembly. A basic 6 inch thick floor panel system has a 4 hour fire resistance rating per UL

K909. For an assembly to be considered “restrained” merely requires that a concrete ring beam, also referred to as a bond beam, be poured around the perimeter of the floor system, with the inclusion of reinforcing steel in the ring beam and in the grouted key joints. Since the concrete and grout pours are integral components of the structural system, once they are completed, so is the fire rated assembly. No additional materials; no additional

labor. One system – exceptional fire rating.

Just as AERCON floor panels provide superb fire resistance, so too do AERCON roof panels. Manufactured and installed just like floor panels, AERCON roof panels have a 4 hour fire resistance rating per UL P932. Whether the fire is above or below the roof, AERCON roof panels provide the peace of mind that your structure is fire resistant.

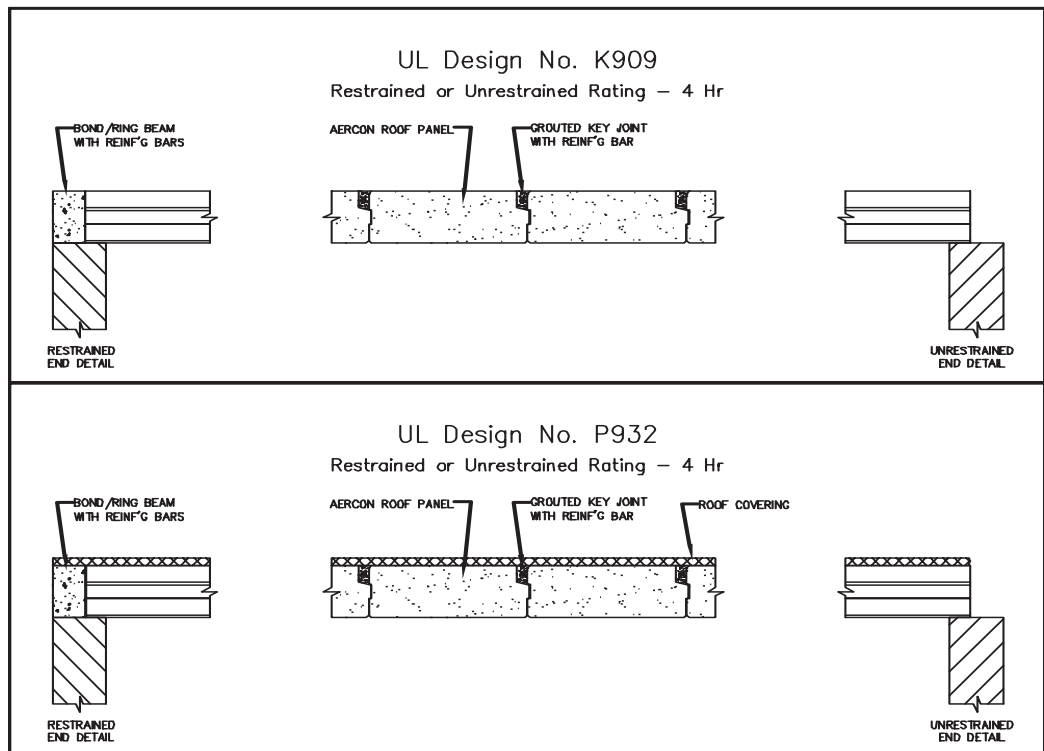

AERCON Reinforced Floor/Roof Panels - 4 Hour Fire Rating (ANSI/UL 263)

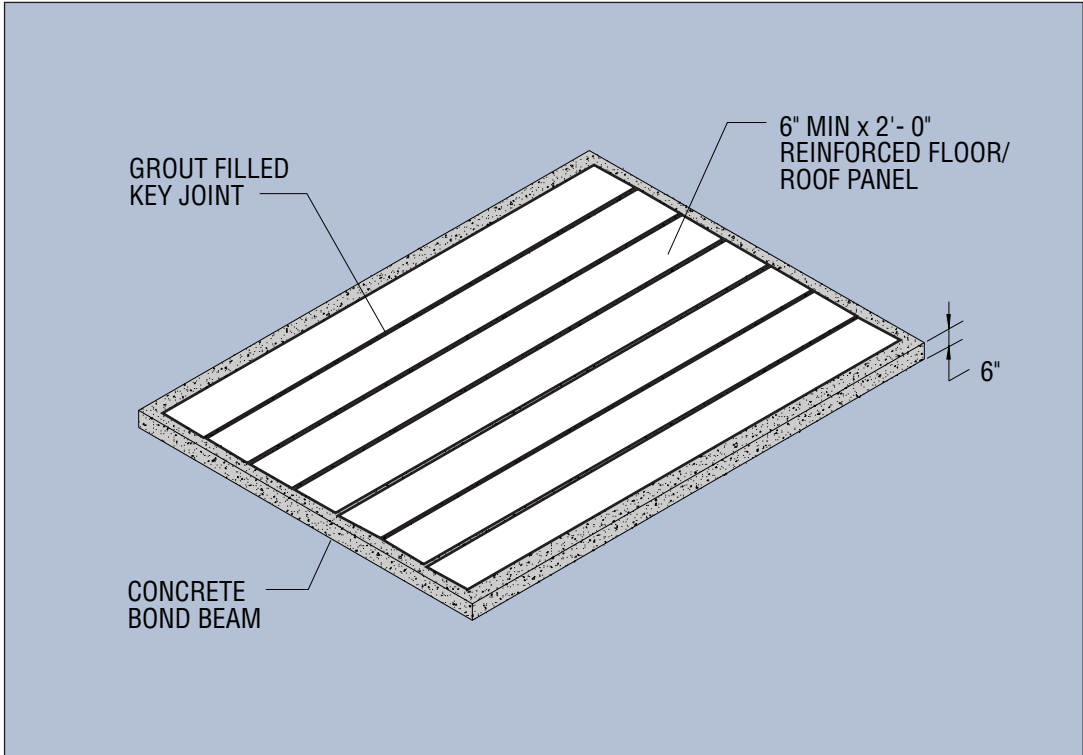

Fire Test Panel Temperatures for 8" Floor/Roof Panels (UL 263)

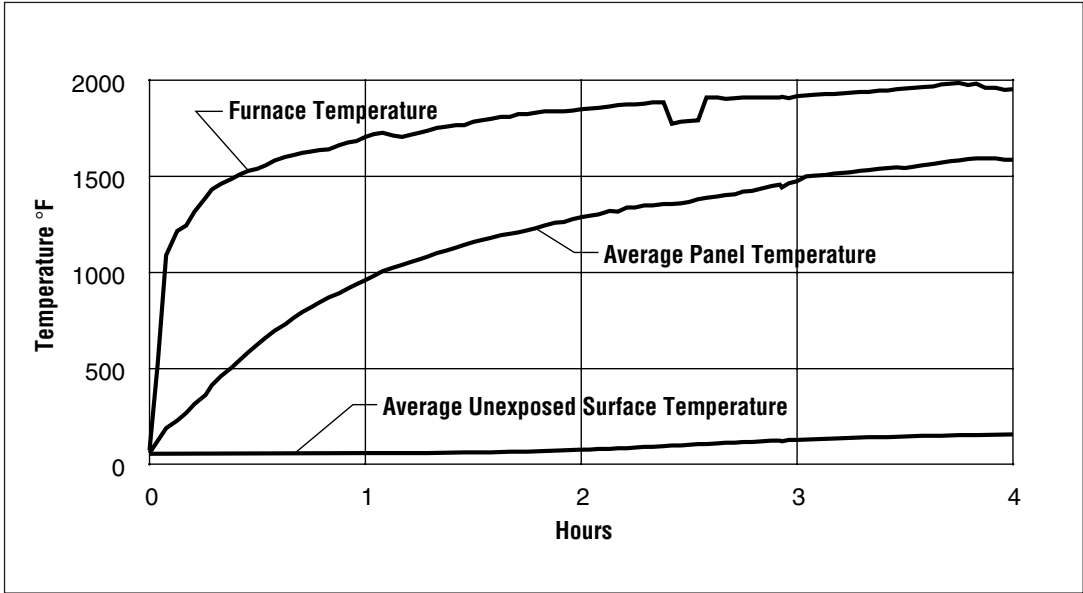

D. Fire Rated Joint Systems

Whenever fire rated elements abut one another, a linear joint or gap is usually created. In order to maintain the integrity of the overall assembly, a fire rated system must be used to seal the joint or gap. There are four primary configurations of joints as illustrated.

The basic standard used to investigate products that are

used in joint systems is ANSI/UL 2079, "Tests for Fire Resistance of Building Joint Systems". The hourly ratings apply only to the complete systems. Individual components are designated for use in a specific system to achieve a specified rating. Each of the joint systems identified are classified as "dynamic", that is, having movement capabilities. All

joint systems are tested at their maximum joint width. The ratings for the joint systems installed in walls apply when either face of the wall is exposed to fire. The ratings for joint systems installed in a floor or roof apply when the underside or ceiling surface is exposed to fire.

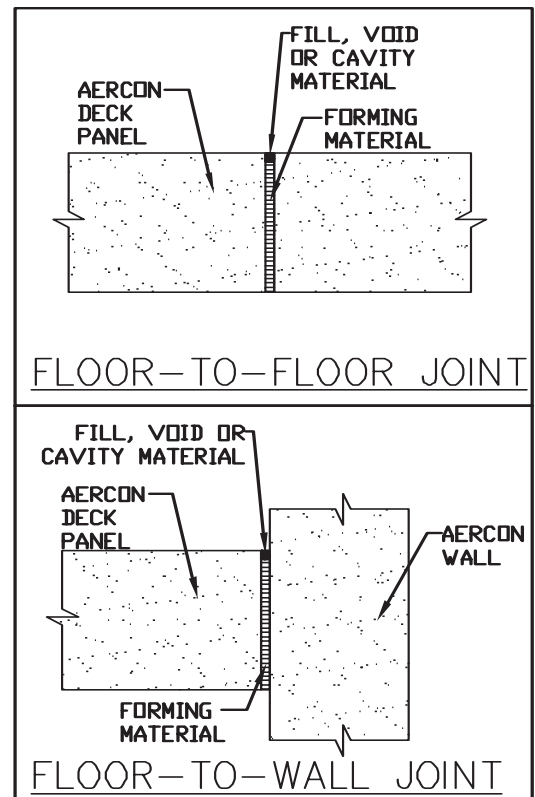
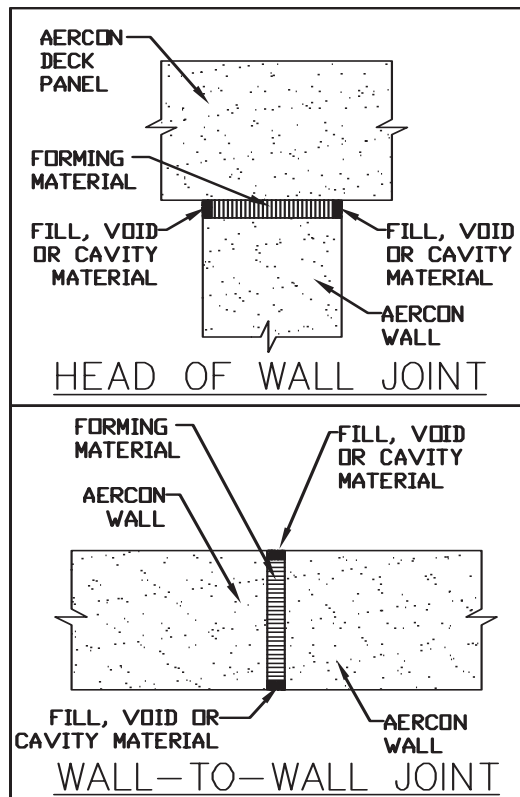

E. Fire Rated Through-Penetration Systems

Whenever a commodity such as piping or electrical wiring must pass through a fire rated element, a circular or rectangular joint or gap is usually created. In order to maintain the integrity of the overall assembly, a fire rated system must be used to seal the joint or gap. A firestop system is a specific configuration of items that consists of a wall or floor assembly, an item that penetrates that wall or floor assembly, and the materials designed to prevent the spread of fire through the opening that is created around the penetrating item. There are currently three through-penetration

firestop systems that can be utilized with AERCON walls and floors. These are illustrated to show the various items associated with each system.

The basic standard used to investigate products that are used in through-penetration systems is ANSI/UL 1479, "Fire Tests of Through-Penetration Firestops". This standard defines the criteria for hourly F and T ratings for firestop systems. The F rating criteria prohibits flame passage through the system and requires acceptable hose stream test performance. The T rating cri-

teria prohibits flame passage through the system and requires the maximum temperature rise (on the side which is not exposed to the fire during testing) to 325°F above the starting temperature and also requires acceptable hose stream test performance. The ratings for firestop systems installed in walls apply when either face of the wall is exposed to fire. The ratings for firestop systems installed in a floor or roof apply when the underside or ceiling surface is exposed to fire.

